



CHARACTERISTICS

- DUAL PUMP MODULES AS STANDARD FOR MAXIMUM UPTIME AND REDUNDANCY.
- QUICK SWAP PUMP MODULES MEAN ZERO DOWNTIME AND DISRUPTION TO PIPE-WORK DURING PUMP MAINTENANCE.
- HIGH OUTPUT AND PRESSURE MAKE LARGE EXTENDED SYSTEMS POSSIBLE:
 - 380 cm³/MIN (22.8 CU. IN/MIN)
 - 2x190 cm³/MIN PER MODULES
- 400 BAR (5880 psi)
- ELECTRICAL DUAL LINE INVERTER INTEGRATES DIRECTLY ONTO OUTLET.
- MINIMUM LEVEL CAPACITANCE SWITCH AND VISUAL MAXIMUM LEVEL AS STANDARD.
- HANDLES-GREASE NLGI 2.
- SUPPLIED ON A FIXING PALLET AS STANDARD FOR EASE OF TRANSPORTATION- AND INSTALLATION.

APPLICATIONS

- HEAVY DUTY APPLICATIONS IN DEMANDING ENVIRONMENTS
- STEEL INDUSTRY
- PULP & PAPER
- CEMENT WORKS
- STEEL PLANT
- OFF-SHORE
- LARGE CRANES AND LOADING EQUIPMENT

ELECTRIC PUMP SOLUTION SUMO II

THE FLEXIBLE HIGH PERFORMANCE HEAVY DUTY

'SUMO II' is the Dropsa electric pump suitable for large single line or dual line systems.

DUAL PUMPING MODULE

A generous 380 cm³/min flow, is provided by twin 190 cm³/min pump modules installed in tandem configuration providing up to 400bar (5880 psi).

The twin pump module provides redundancy for high uptime – it allows the system to continue working even if one pump module becomes ineffective.

INSTRUMENTATION MODULES

Sophisticated add on instrumentation modules and options means even complex requirements can be met with off-the-shelf standard product.

QUICK SWAP SYSTEM

BOTH PUMPING MODULES can be quickly replaced from the front mounting of the pump. No pipe work needs to be disrupted meaning near-zero downtime during maintenance.

DUAL LINE OR SINGLE LINE IS EASY

The outlet plate fixing system has both Pressure and Return ports. The outlets are directly compatible with Dropsa's electrical or pneumatic line inverters (including Modular version).



DUAL LINE SYSTEM

SIMPLE AND RELIABLE PARTICULARLY IN HARSH ENVIRONMENTAL

Lubrication systems engineered with the Dual Line System are generally used on large scale machinery and in harsh operating conditions to lubricate multiple points on large machines. The system can grow to a very complex one with a length that often can exceed 60 meters. The large section of pump packages together with many custom design options allows any lubrication system to be developed reliably and cost-effectively.

ADVANTAGES:

1. Adjustable pump element: available as optional.
2. Reduced Investment: with Dual Pumping Modules, the system can continue even if one pump module becomes ineffective providing redundancy and reducing need for a complete second standby pump.
3. Fast maintenance: Quick swap pump modules can be replaced in seconds. Pipe work untouched means less chances of contamination.
4. Compact modular design: eliminates EXTERNAL PIPING OF COMPONENTS.

LINE 1

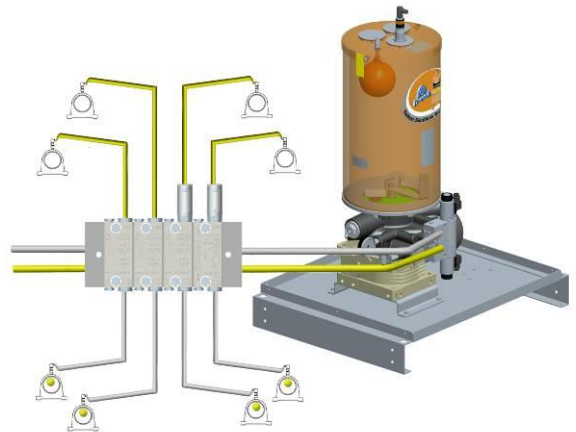

LINE 2

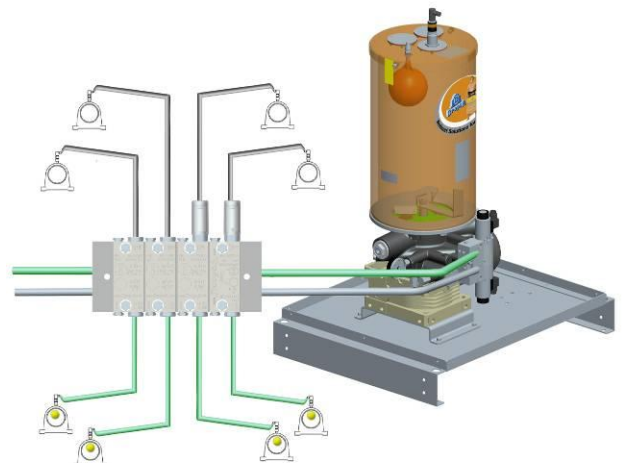

TECHNICAL INFORMATION

	TECHNICAL CHARACTERISTICS
Max pressure	5880 psi (400 bar)
Output Flow Delivery	380 cm ³ / min (22.8 cu. in/min) total (standard) 190 cm ³ (11.59 cu. in) single pumping
Operating Temperature	- 10 ÷ + 50 °C (+14÷122F)
Operating Humidity	90% max
Protection grade	IP 55
Viscosity at operating temperature	Mineral oil lubricants Min. 32 cSt max. 1000 cSt
	Grease lubricants NGLI 2 Max.

DIMENSIONS (NOT TO SCALE)

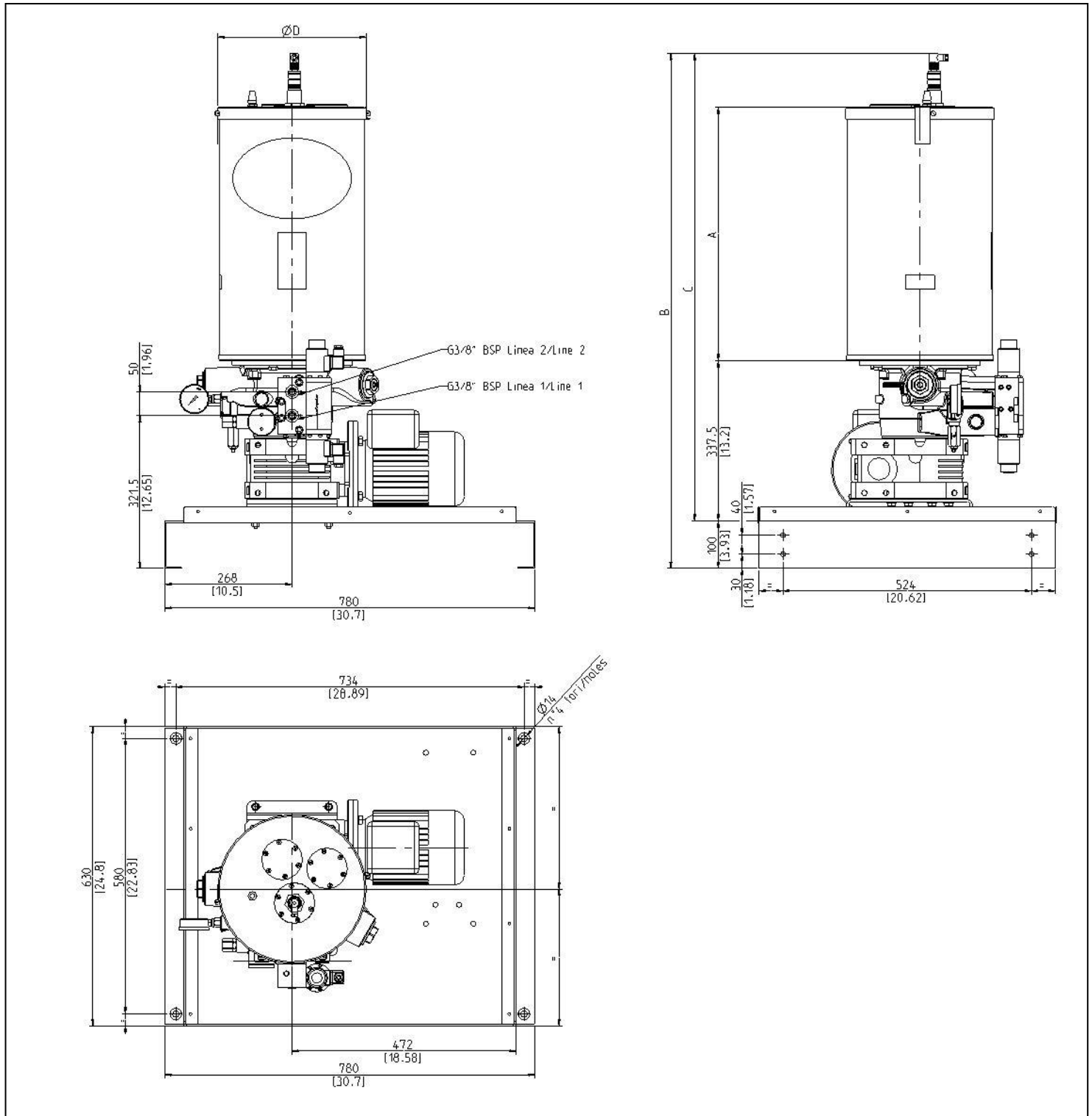

OPTIONAL

			Q.TY
Oil conversion	Min/max oil level float kit 30 Kg (66lb)	<input type="radio"/>	0295150
	Min/max oil level float kit 100 Kg (220lb)	<input type="radio"/>	0295160
	Filling cap with filter	<input type="radio"/>	3130138
Terminal Box bracket	Bracket for installing a terminal wiring box onto the base pallet	<input type="radio"/>	3044455
Terminal	Terminal box	<input type="radio"/>	0291655
Electrical control box Bracket	Bracket for installing a control box onto the base pallet	<input type="radio"/>	3044456
Metal pallet	Metal Pallet used as the base of the packaging and also for installation of the pump	<input type="radio"/>	0297150

SPARE PARTS

			Q.TY
Motors	3Ph - 0,75 Kw IE2- 230Δ/400Y 50Hz 280Δ/480Y 60Hz	<input type="radio"/>	3301081
	3Ph UL e CSA - 0,75 Kw IE2- 230Δ/400Y 50H 280Δ/480Y 60Hz	<input type="radio"/>	3301528
Reducer i=40		<input type="radio"/>	3301608
Maximum mechanical level kit meccanico 30 e 100 Kg (grasso)		<input type="radio"/>	0295100
Laser probe assembly 30÷100 Kg - 24V cc Out NO e NC (1 threshold)		<input type="radio"/>	0295131
Laser level kit 24V cc Out 4÷20mA/2 NO (4 thresholds) – 30 Kg		<input type="radio"/>	0295130
Laser level kit 24V cc Out 4÷20mA/2 NO (4 thresholds) – 100 Kg		<input type="radio"/>	
Minimum level kit (250V AC) 30 kg (grease)		<input type="radio"/>	0295121
Minimum level kit (250V AC) 100 kg (grease)		<input type="radio"/>	0295122
Grease loading filter		<input type="radio"/>	0295009
By-pass		<input type="radio"/>	0234815
Pressure gauge 0 - 600 Bar		<input type="radio"/>	3292171
Pumping		<input type="radio"/>	0296080

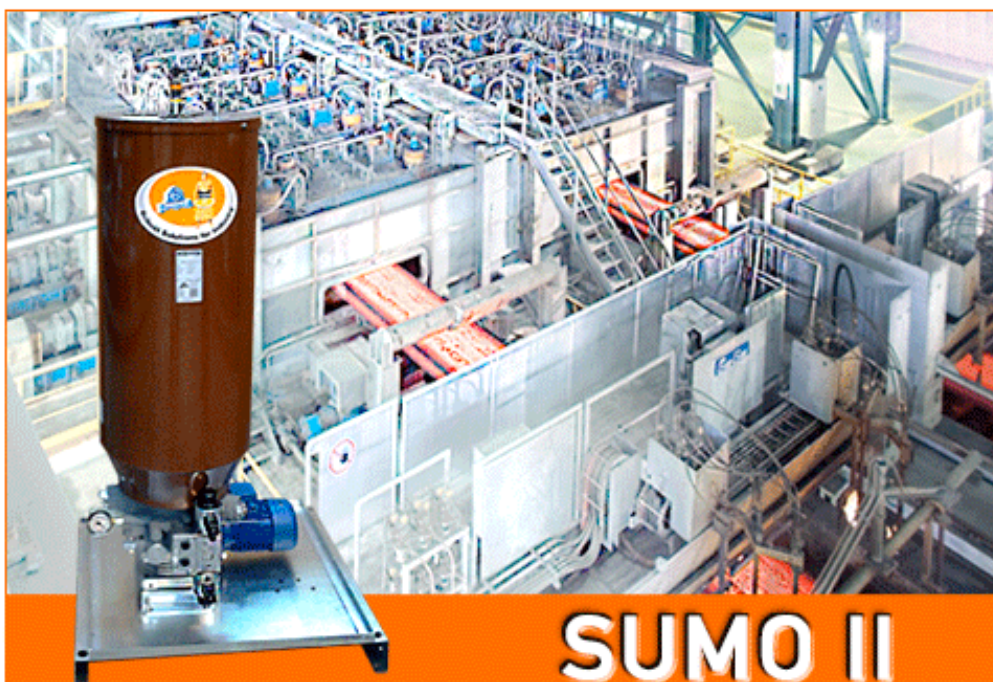

SUMO II

Info Distributor: