

RE 18305-09/12.13

4/3 - 4/2 Directional valve with solenoid actuation

L511... (LC1-DZ)

Size NG6 ISO 4401-03 CETOP RP121 H-03 (CETOP 3)
Series 00
Maximum operating pressure 310 bar [4500 psi]
Maximum flow 50 l/min [13.2 gpm]



DVI0105

Summary

Description	
General specifications	
Ordering details	
Spool variants	
Principles of operation, cross section	
Technical Data	
Δp - Q_v characteristic curves	
Performance limits	
External Dimensions and Fittings	
Electric connections	

General specifications

Page	
1	- Valve elements with solenoid operated directional spool.
2	- Control spools operated by solenoids with removable coils.
3	
4	- In the de-energized condition, the control spool is held in the central position by return springs.
4	
6	- Wet pin tubes for DC coils, with push rod for mechanical override; nickel plated surface.
6	
7	- Coils can be rotated 360° around the tube; they can be energized by AC current through special connectors with rectifier (RAC).
9	
	- Manual override (push-button or screw type) available as option.

Ordering Details

L	5	1	1	1	1	1	1
---	---	---	---	---	---	---	---

Family
Directional Valves
Cetop 3

Type
Size 6

Coil
C45

Circuit
4/3 operated on both sides A and B = 2
4/2 operated on side A only = 3
4/2 operated on side B only = 4

Options

-- = Lever type manual override ²⁾
00 = Standard
0P = Push-button type manual override
0F = Screw type manual override

Electric connections

00 = Without coils
01** = With coils, without mating connector DIN EN 175301-803
03 = With coils, with bi-directional diode, without mating connector vertical Amp-Junior
07 = With coils, with bi-directional diode, without mating connector DT04-2P
-- = Special

Voltage supply

00 =					Without coil
OB =	■	■	■	■	12V DC
AD =	■	■	■	■	13V DC
OC =	■	■	■	■	24V DC
AC =	■	■	■	■	27V DC
OD =				■	48V DC
OE =				■	110V DC
OV =				■	(21.5 DC) 24V AC
OW =				■	(98 DC) 110V AC
OZ =				■	(207 DC) 230V AC

07 03 01 00

Available connections

Spool variants

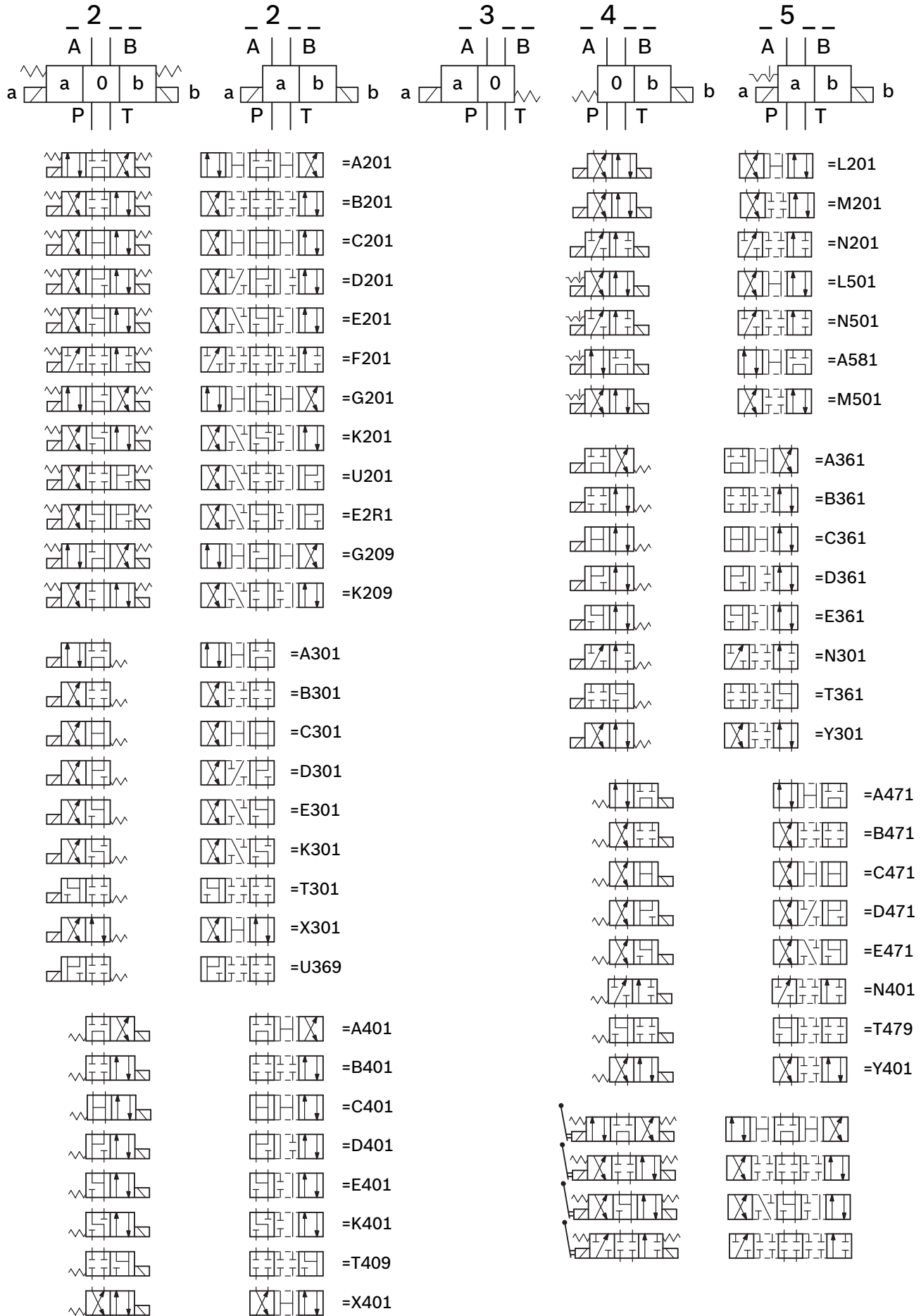

Principles of operation, cross section

The sandwich plate design directional valve elements L511... are compact direct operated solenoid valves which control the start, the stop and the direction of the oil flow. These elements basically consist of a stackable housing (1) with a control spool (2), one or two solenoids (5), and one or two return springs (4). When energized, the force of the solenoid (5) pushes the control spool (2) from its neutral-central position "0" to the required end position "a" or "b", and the

required flow from P to A (with B to T), or P to B (with A to T) is achieved. Once the solenoid is de-energized, the return spring (4) pushes the spool thrust washer (3) back against the housing and the spool returns in its neutral-central position.

Each coil is fastened to the solenoid tube by a ring nut (6). A pin (7) allows to push the spool (2) in emergency conditions, when the solenoid cannot be energized, like in case of voltage shortage.

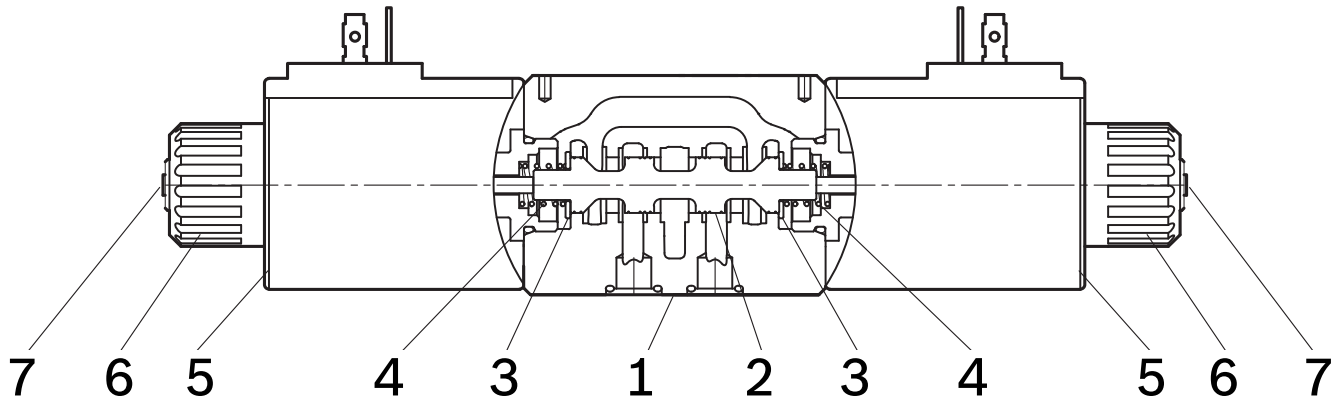

Technical Data (for applications with different specifications consult us)

General

Valve element with 2 solenoids	kg [lbs]	1.82 [4.0]
Valve element with 1 solenoid	kg [lbs]	1.33 [2.9]
Valve element with 2 solenoids, with lever type emergency	kg [lbs]	2.1 [4.6]
Valve element with 1 solenoid, with lever type emergency	kg [lbs]	1.6 [3.5]
Ambient Temperature	°C [°F]	-20....+50 [-4....+122] (NBR seals)

Hydraulic

Maximum pressure at P, A and B ports	bar [psi]	310 [4500]
Maximum pressure at T	bar [psi]	250 [3625]
Max pressure, with lever type emergency at T	bar [psi]	200 [2900]
Maximum inlet flow	l/min [gpm]	50 [13.2]
Hydraulic fluid		Mineral oil based hydraulic fluids HL (DIN 51524 part 1). Mineral oil based hydraulic fluids HLP (DIN 51524 part 2). For use of environmentally acceptable fluids (vegetable or polyglycol base) please consult us.
Fluid Temperature	°C [°F]	-20....+80 [-68....+176] (NBR seals)
Permissible degree of fluid contamination		ISO 4572: $\beta_{x \geq 75} X=12...15$ ISO 4406: class 20/18/15 NAS 1638: class 9
Viscosity range	mm ² /s	5...420

Electrical

Voltage type	DC (AC only with RAC connection)									
Voltage tolerance (nominal voltage)	%	-10 +10								
Duty	Continuous, with ambient temperature $\leq 50^{\circ}\text{C}$ [122°F]									
Coil wire temperature not to be exceeded	$^{\circ}\text{C}$ [°F]	150 [302]								
Insulation class	H									
Compliance with	Low Voltage Directive LVD 73/23/EC (2006/95/EC), 2004/108/EC									
Coil weight with connection EN 175301-803	kg [lbs]	0.335 [0.74]								
Voltage	V	12	13	24	27	48	110	24 +RAC (21,5)	110 +RAC (98)	230 +RAC (207)
Voltage type		DC	DC	DC	DC	DC	DC	DC	DC	DC
Power consumption	W	33	31	33	33	33	35	33	33	35
Current (nominal at 20°C [68°F])	A	2.8	2.3	1.4	1.2	0.7	0.32	1.6	0.34	0.16
Resistance (nominal at 20°C [68°F])	Ω	4.24	5.42	17	21.8	69.8	341.8	13.6	285	1229

	Voltage (V)	Connector type	Code	Marking	Coil Mat no.
=OB 01	12 DC	EN 175301-803 (Ex. DIN 43650)	C4501 12DC	12 DC	R933000026
=OB 03	12 DC	AMP JUNIOR	C4503 12DC	12 DC	R933000027
=OB 07	12 DC	DEUTSCH DT 04-2P	C4507 12DC	12 DC	R933000030
=AD 01	13 DC	EN 175301-803 (Ex. DIN 43650)	C4501 13DC	13 DC	R933000028
=AD 03	13 DC	AMP JUNIOR	C4503 13DC	13 DC	R933000029
=AD 07	13 DC	DEUTSCH DT 04-2P	C4507 13DC	13 DC	R933000031
=OC 01	24 DC	EN 175301-803 (Ex. DIN 43650)	C4501 24DC	24 DC	R933000034
=OC 03	24 DC	AMP JUNIOR	C4503 24DC	24 DC	R933003630
=OC 07	24 DC	DEUTSCH DT 04-2P	C4507 24DC	24 DC	R933000032
=AC 01	27 DC	EN 175301-803 (Ex. DIN 43650)	C4501 27DC	27 DC	R933000035
=AC 03	27 DC	AMP JUNIOR	C4503 27DC	27 DC	R933000036
=AC 07	27 DC	DEUTSCH DT 04-2P	C4507 27DC	27 DC	R933000033
=OD 01	48 DC	EN 175301-803 (Ex. DIN 43650)	C4501 48DC	48 DC	R933000037
=OE 01	110 DC	EN 175301-803 (Ex. DIN 43650)	C4501 110DC	110 DC	R933000040
=OV 01	24 RAC	EN 175301-803 (Ex. DIN 43650)	C4501 21.5DC	21.5 DC	R933000038
=OW 01	110 RAC	EN 175301-803 (Ex. DIN 43650)	C4501 98DC	98 DC	R933000039
=OZ 01	230 RAC	EN 175301-803 (Ex. DIN 43650)	C4501 207DC	207 DC	R933000041

Characteristic curves

Measured with hydraulic fluid ISO-VG32 at $45^\circ \pm 5^\circ \text{ C}$ [$113^\circ \pm 9^\circ \text{ F}$]; ambient temperature 20° C [68° F].

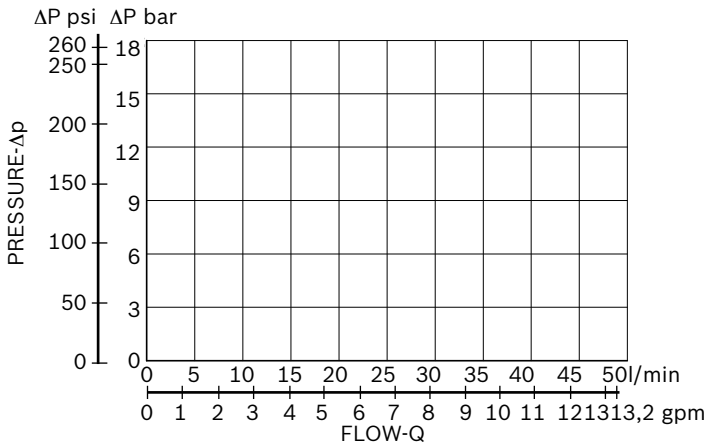

Performances limits

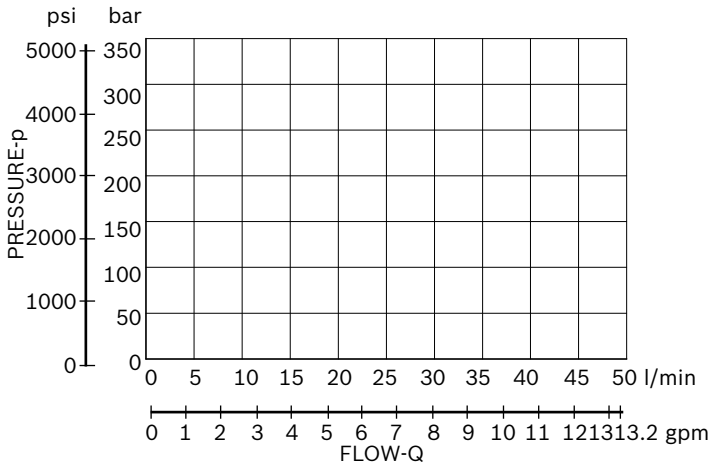

Minimum flow for efficiency of LS control

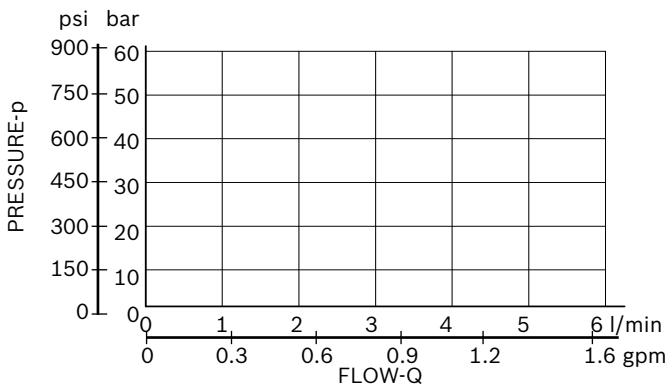

External Dimensions and Fittings

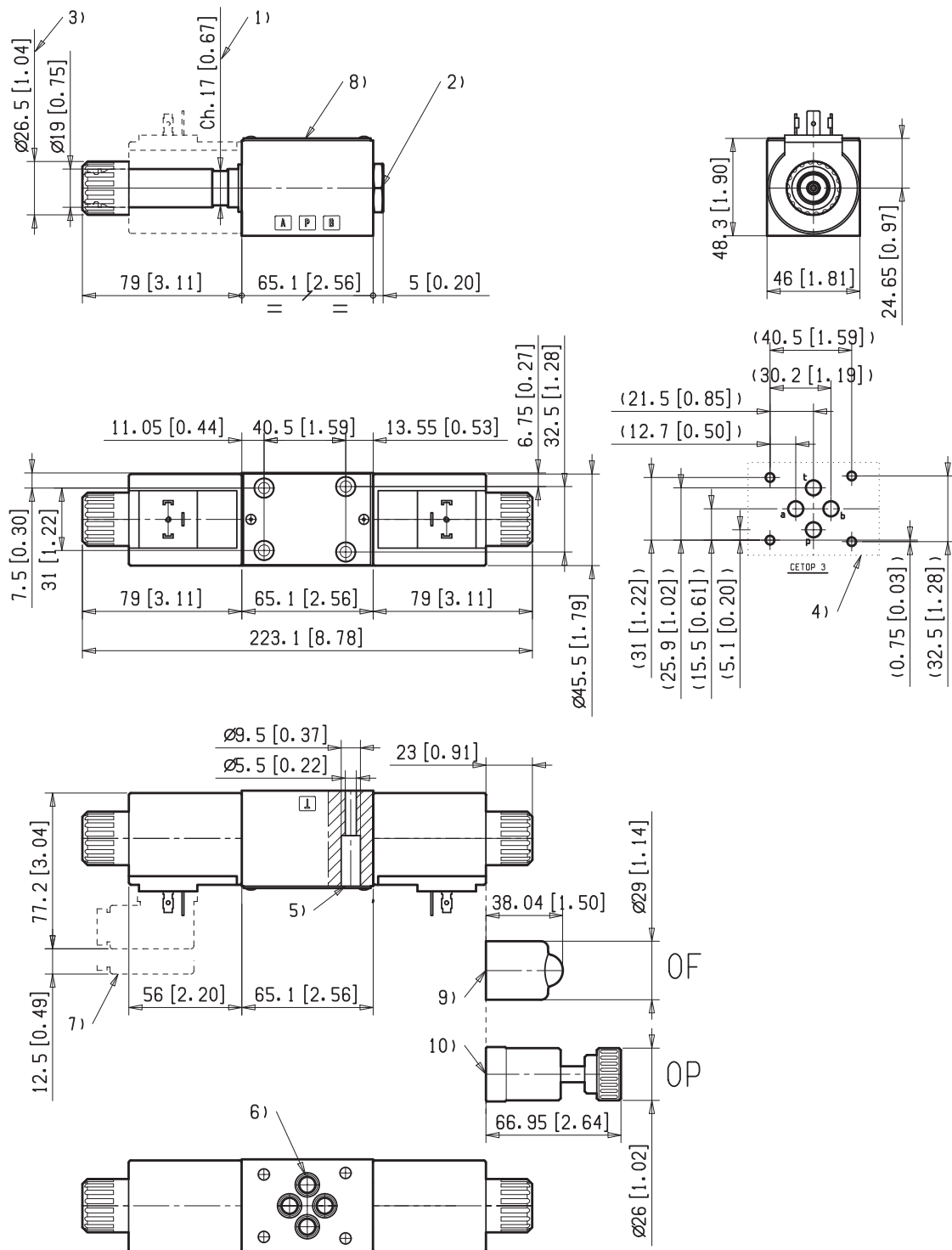

1 Solenoid tube $\varnothing 19$ mm [0.75 inch].

2 Plug for two position version

3 Ring nut for coil locking ($\varnothing 26.5$ mm); torque 3-4Nm [2.2-3 ft-lb].

4 Flange specifications Cetop3

5 Four threaded holes M5 for fitting a secondary flangeable element. Bolts M5 with recommended strength class DIN 8.8; torque 5-6 Nm [3.6-4.4 ft-lb].

6 O-Rings for P-T-A-B ports.

7 Clearance needed for connector removal.

8 Identification label.

9 Optional push-button manual override, OP type, for spool opening: it is pressure stuck to the ring nut for coil locking. Mat no. R933000043.

10 Optional screw type manual override, OF type, for spool opening: it is screwed (torque 6-7 [4.4-5.2 ft-lb]) to the tube as replacement of the coil ring nut. Mat no. R933007215.

External Dimensions and Fittings

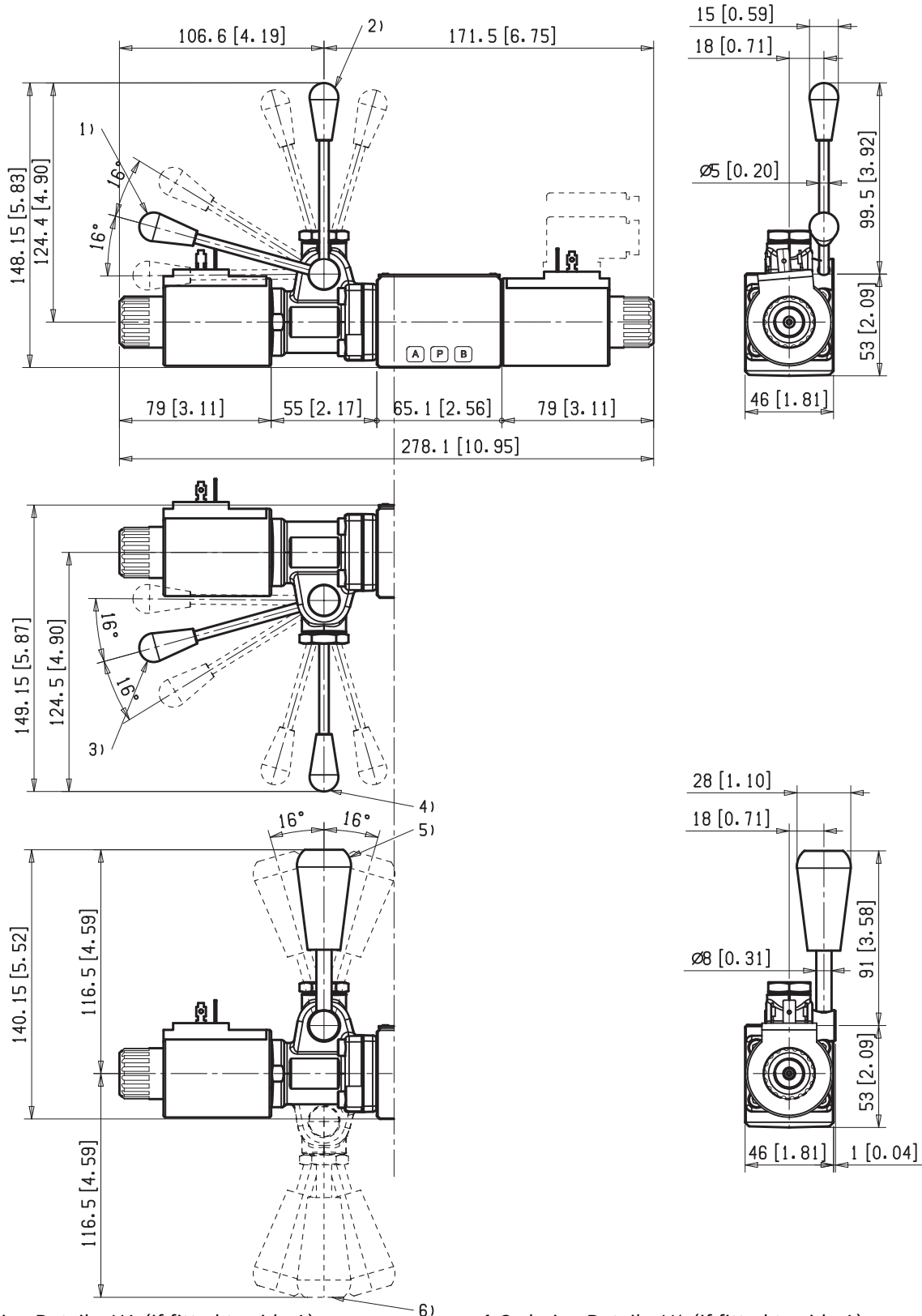

1 Ordering Details: HA (if fitted to side A)
or HB (if fitted to side B).

2 Ordering Details: VA (if fitted to side A)
or VB (if fitted to side B).

3 Ordering Details: H1 (if fitted to side A)
or H9 (if fitted to side B).

4 Ordering Details: V1 (if fitted to side A)
or V9 (if fitted to side B).

5 Ordering Details: XA (if fitted to side A)
or XB (if fitted to side B).

6 Ordering Details: X1 (if fitted to side A)
or X9 (if fitted to side B).

Electric connections

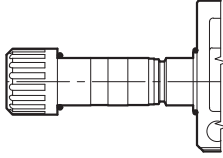
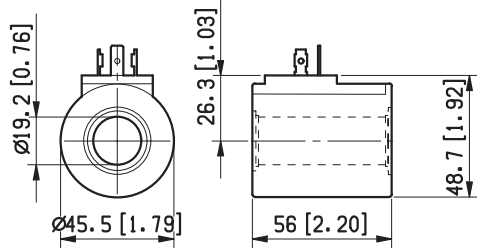
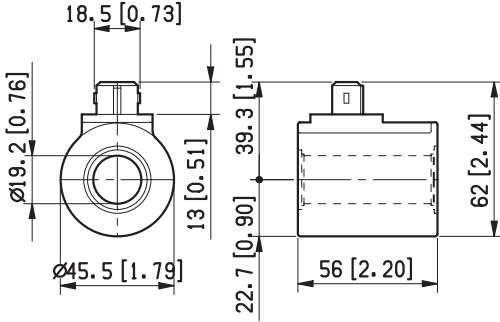
<p>=00</p>		<p>=01</p>	
<p>=03</p>	<p>Protection class: IP 65 with female connector properly fitted (see drawing).</p> 	<p>=07</p>	<p>Protection class: IP 69 K with female connector properly fitted (see drawing).</p> 