

SPLIT-SHAFT UNIT 2000 KGM 3.2.90.3.
3000 KGM 3.2.90.4.



- ✓ Inserted in the driveshaft between gearbox and rear axle.
- ✓ PTO shaft torque capability: 110 kgm max at 2000 rpm.
- ✓ Two - one to front, one to rear - independently shiftable PTO's for hydraulic pumps or prop-shaft drive.
- ✓ "Constant-mesh" output options on request.
- ✓ Clutch unit p.n. 3.5.1.068.0000 capable of 60 kgm suitable for "constant-mesh" output direct mounting.
- ✓ Two auxiliary PTO outputs available on request off the idler shaft with 4.2.00.01 independent engagement.
- ✓ Auxiliary power available with the vehicle in motion.
- ✓ Drive connection to rear axle independent on PTO operation.
- ✓ Provision for electronic tachograph (Mannesmann VDO type):
code 0.99.00.740.00 (dynamic with faston-type joint),
code 0.99.00.741.00 (static with faston-type joint),
code 0.99.00.742.00 (static with plug type joint).
- ✓ Versions predisposed for oil cooling kit or with kit already mounted.
- ✓ Max throughput rpm:
- standard unit: **2.200 rpm**
- with oil cooling kit: **3.700 rpm**

TORQUE RATING THROUGH THE MAIN DRIVE SHAFT:

2000 kgm for 3.2.90.3 - 3000 kgm for 3.2.90.4

AVAILABLE PTO OUTPUT RATIOS: 1,28:1

ROTATION: engine

WEIGHT 3.2.90.3: kg. 109 (without flanges)

3.2.90.4: kg. 111,4 (without flanges)

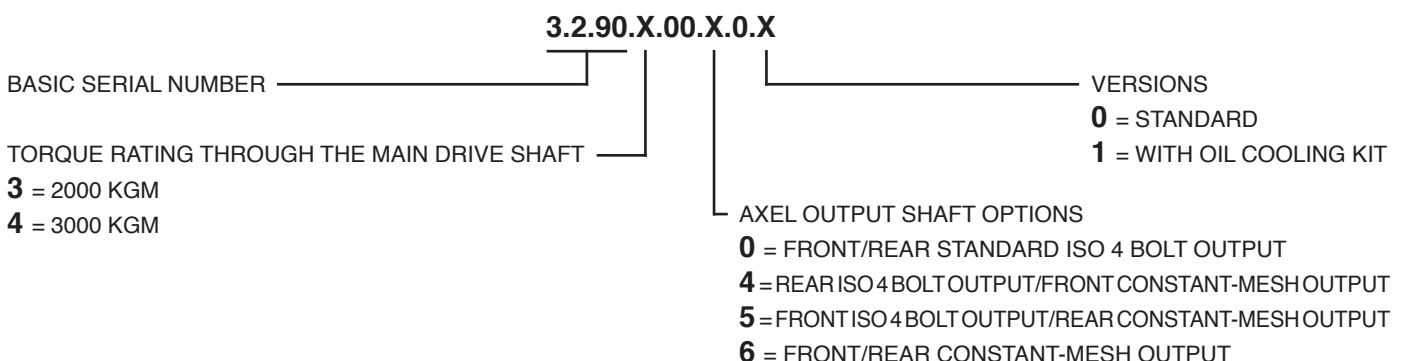

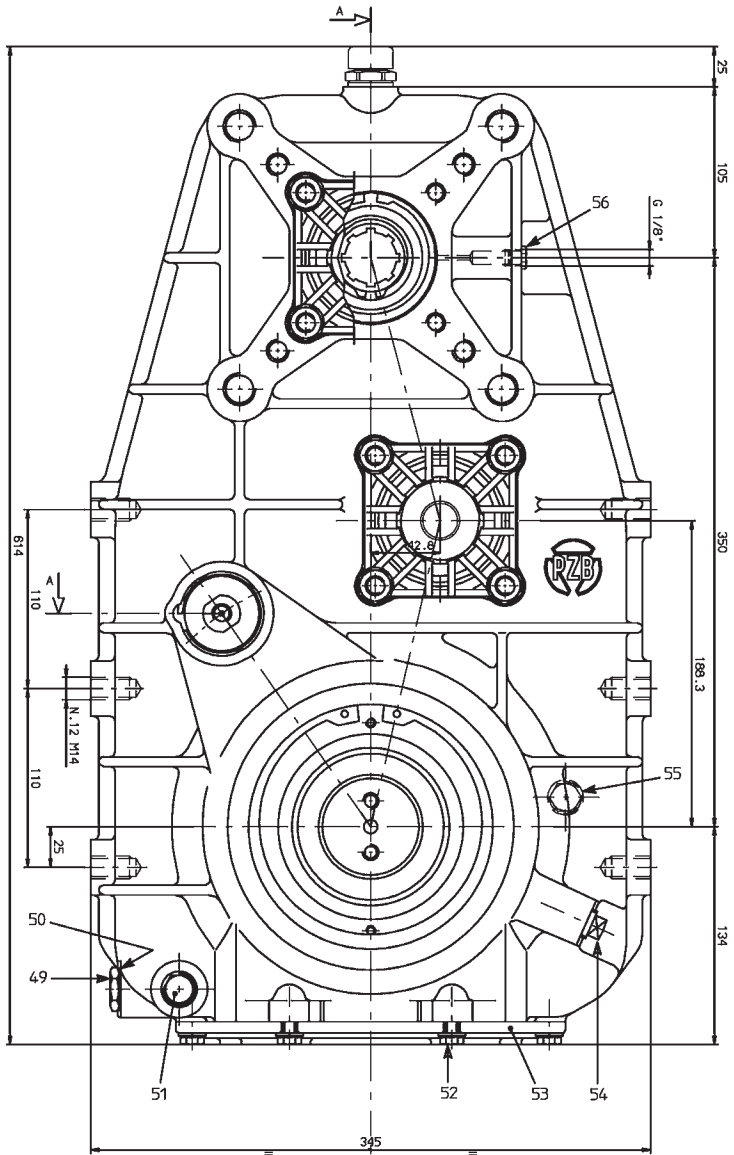

REAR VIEW

VERSION 3.2.90.3.

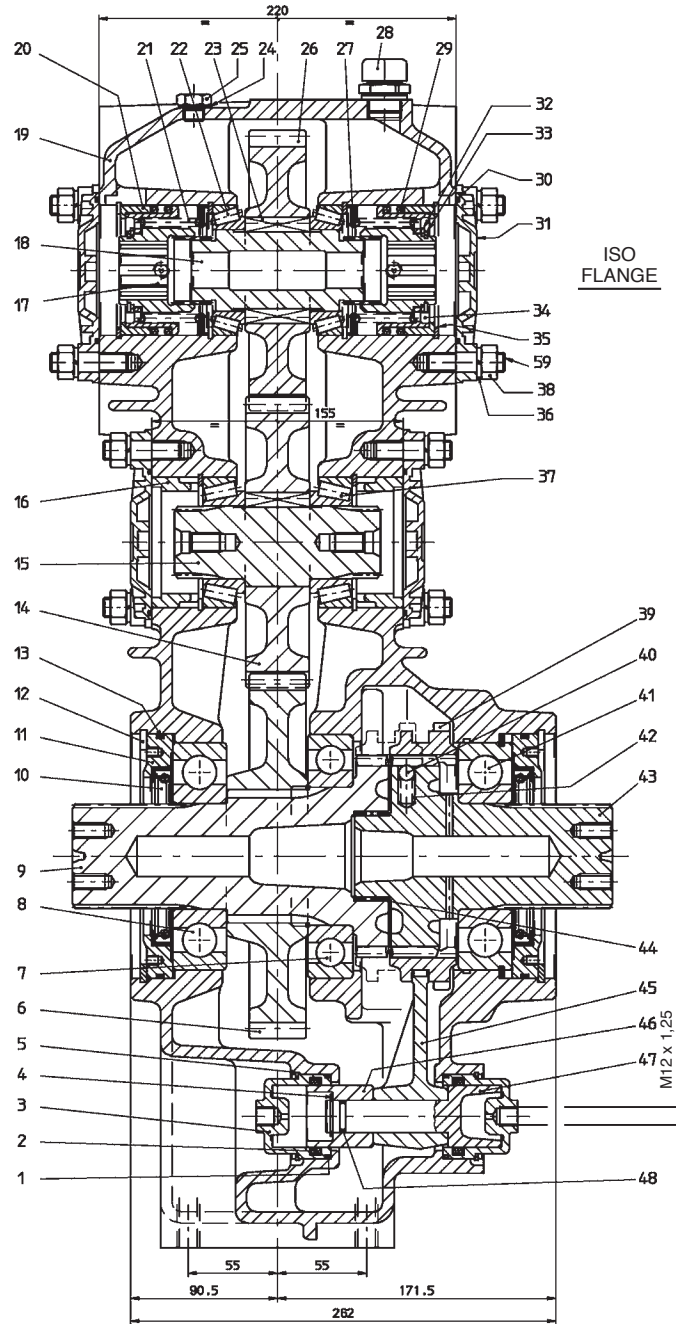

SECTION A-A

FRONT OF VEHICLE

VERSION 3.2.90.4.

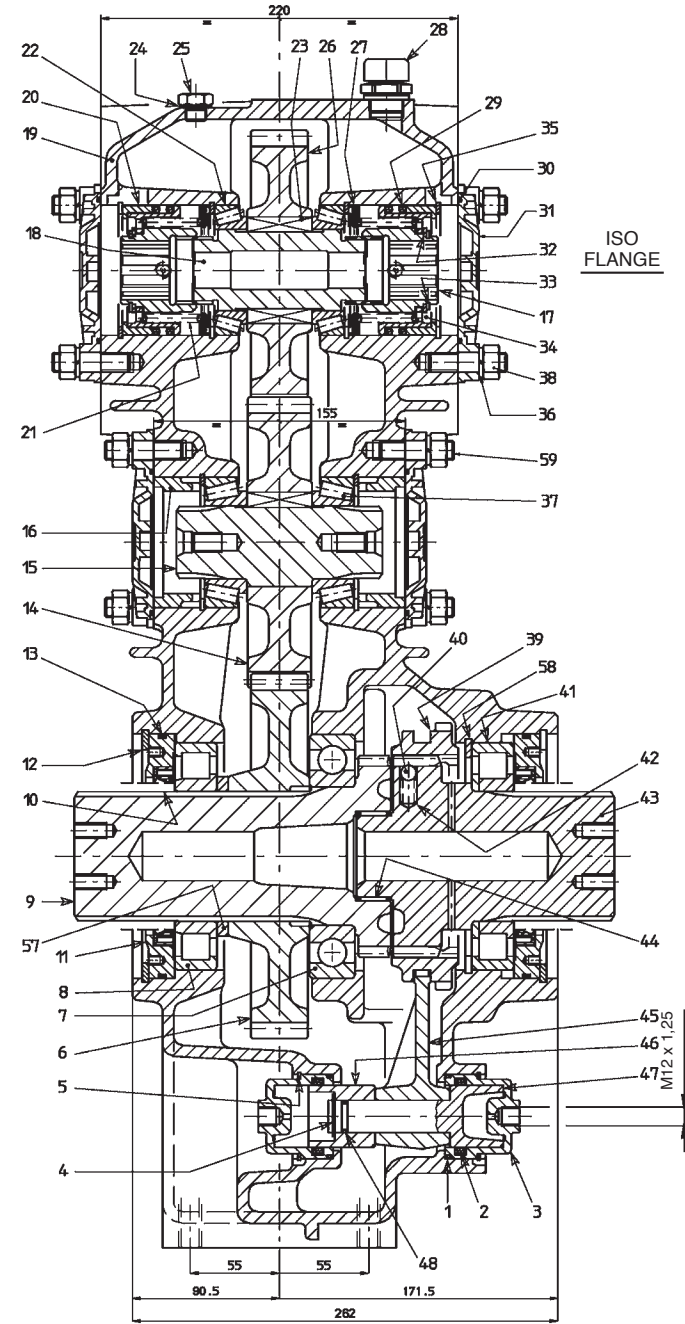

SECTION A-A

FRONT OF VEHICLE

REF.	CODE	DESCRIPTION	QT.	REF.	CODE	DESCRIPTION	QT.
1	0.08.02.138.00	O-Ring OR 3187 Viton	2	29	0.08.02.119.00	O-Ring OR 6275 Viton	4
2	0.08.02.137.00	O-Ring OR 6150 Viton	2	30	0.08.02.163.00	O-Ring OR 83,8x2,62 DIN 3770 Viton	4
3	1.08.01.001.00	Cylinder 218B/5	2	31	1.24.01.110.00	Cover	4
4	0.07.01.022.00	Circlip 20e UNI 7435	1	32	1.26.01.085.00	Spacer	2
5	0.07.05.002.00	Circlip SB52	2	33	0.07.01.016.00	Circlip 42e UNI 7435	2
6	1.11.03.107.00	Gear 50 T (P.T.O. 3.2.90.3)	1	34	1.21.02.025.00	Piston	2
	1.11.03.109.00	Gear 50 T (P.T.O. 3.2.90.4)	1	35	0.07.02.012.00	Circlip 80i UNI 7437	6
7	0.10.01.042.00	Bearing 6217	1	36	0.04.08.002.00	Lockwasher 12,5 DIN 7980	16
8	0.10.01.040.00	Bearing 6313 (P.T.O. 3.2.90.3)	1	37	0.10.05.029.00	Bearing 33109	2
	0.10.03.021.00	Bearing NJ 216 (P.T.O. 3.2.90.4)	1	38	0.03.01.019.00	Hex nut M12 ch. 17	16
9	1.13.01.151.00	Shaft (P.T.O. 3.2.90.3)	1	39	1.17.02.080.00	Splined sleeve	1
	1.13.01.161.00	Shaft (P.T.O. 3.2.90.4)	1	40	0.11.01.002.00	Ball 3/8"	3
10	0.08.01.091.00	Seal 90x110x12 Viton	2	41	0.10.01.041.00	Bearing 6313NR (P.T.O. 3.2.90.3)	1
11	1.27.02.122.00	Ring	2		0.10.03.022.00	Bearing NUP 216 (P.T.O. 3.2.90.4)	1
12	0.07.02.046.00	Circlip 150i UNI 7437	2	42	1.28.01.006.00	Coil spring mod.15	3
13	0.08.02.140.00	O-Ring OR 4562 Viton	2	43	1.13.01.152.00	Shaft (P.T.O. 3.2.90.3)	1
14	1.11.10.112.00	Gear 40 T	1		1.13.01.162.00	Shaft (P.T.O. 3.2.90.4)	1
15	1.13.02.043.00	Shaft	1	44	0.10.06.017.00	Needle cage K50x55x20H	1
16	1.27.02.043.00	Centering ring	2	45	1.22.01.044.00	Fork	1
17	1.17.02.071.00	Splined sleeve	2	46	1.21.02.038.00	Piston	1
18	1.13.02.040.00	Shaft	1	47	1.21.01.030.00	Piston	1
19	1.01.05.014.00	Housing	1	48	0.08.02.136.00	O-Ring OR 119 Viton	1
20	1.27.02.079.00	Ring	2	49	0.12.01.024.00	Plug G1/2"	1
21	1.28.01.075.00	Coil spring	2	50	0.04.01.039.00	Washer 26x20x1	1
22	0.10.05.027.00	Bearing 32010X	2	51	0.12.01.002.00	Plug FIAT 1/43262/11	1
23	0.06.01.018.00	Key 14x9x40 UNI 6604 - type "B"	3	52	0.01.01.076.00	Capscrew TE with flange M8x20 DIN 6921	6
24	0.04.01.077.00	Washer 13,5x19x1,5	1	53	1.24.01.094.00	Cover	1
25	1.30.03.029.00	Plug G1/4"	1	54	0.12.01.049.00	Plug 18x1,5 FIAT 1/43236/11	1
26	1.11.10.108.00	Gear 39 T	1	55	0.12.01.065.00	Plug 22x1,5 FIAT 1/43244/11	1
27	1.26.01.132.00	Ring	2	56	0.12.01.059.00	Plug U-908G1/8	2
28	0.12.01.115.00	Filler-breather G1/2"	1	57	1.26.01.122.00	Spacer (P.T.O. 3.2.90.4)	1
				58	0.07.02.047.00	Circlip 140i UNI 7437 (P.T.O. 3.2.90.4)	1
				59	0.02.02.031.00	Stud M12x30 UNI 5911	16

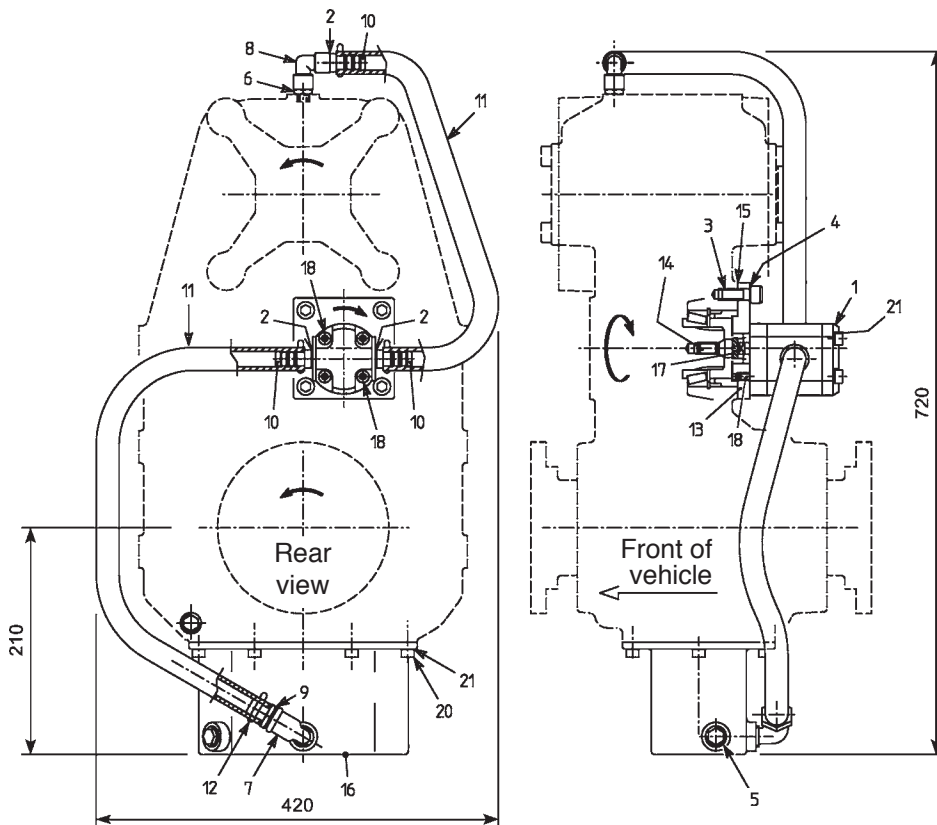

**OIL COOLING KIT
CODE 2.05.415.0000**

**SPLIT-SHAFT UNIT
CODE 3.2.90.3.0000.1
CODE 3.2.90.4.0000.1**

REF.	CODE	DESCRIPTION	QT.	REF.	CODE	DESCRIPTION	QT.
1	0.00.09.010.00	Gear pump 10A1x385 sx 1cc 2att 3/8	1	11	0.99.00.268.00	Outlet hose 16x24 lungh. 600 mm	2
2	0.04.01.063.00	Washer 22x17x1,5	3	12	0.99.00.269.00	Jubilee clip	4
3	0.01.03.067.00	Capscrew TCEI M12x30 UNI 5931 CL RES 8.8	4	13	1.07.02.043.00	Flange	1
4	0.04.04.002.00	Washer Schnorr ø 12	4	14	1.17.03.020.00	Coupling	1
5	0.12.01.002.00	Plug M12x1,5	1	15	1.29.01.014.00	Gasket	1
6	0.13.00.059.00	G1/4" - G3/8", M straight fitting	1	16	1.99.00.308.00	Oil sump	1
7	0.13.00.054.00	G1/2", M-F elbow fitting	1	17	1.17.03.019.00	Coupling	1
8	0.13.00.058.00	G3/8", 2 F 90° elbow fitting	1	18	0.01.03.032.00	Capscrew TCEI M8x80 UNI 5931	2
9	0.13.00.056.00	G1/2" M fitting for 16 mm ID hose	1	20	0.01.03.010.00	Capscrew TCEI M8x20 UNI 5931	6
10	0.13.00.057.00	G3/8" M fitting for 16 mm ID hose	3	21	0.04.04.003.00	Washer Schnorr ø 8	8

