

DENISON HYDRAULICS

Pressure Relief Valve R4V

Proportional Pressure Relief Valve R4V...P2

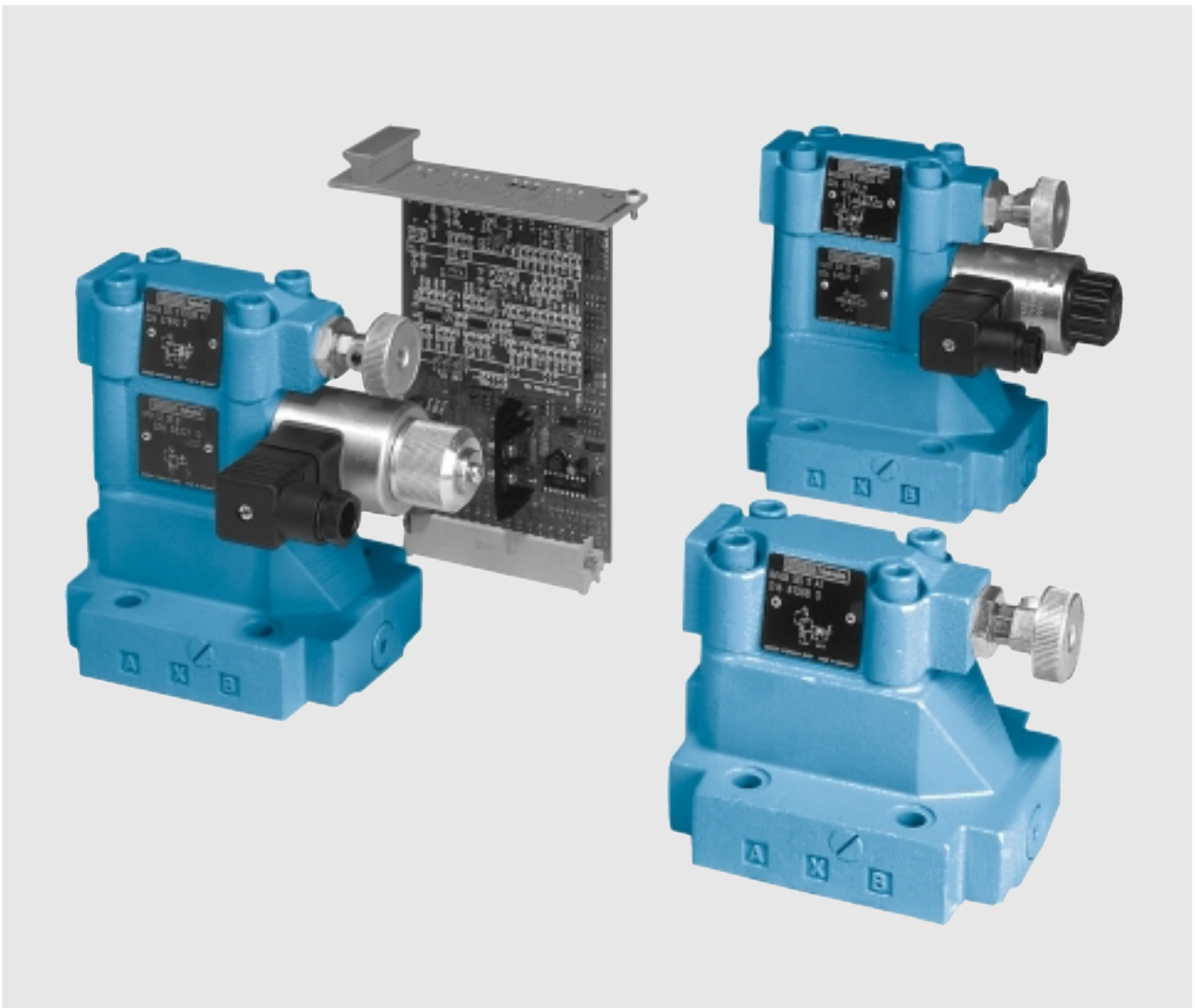

Publ. 3-EN 2400-B, replaces 3-EN 2400-A

DENISON Hydraulics

FEATURES, SYMBOL

FEATURES

- **High Performance:** R4 valves are designed for a maximum pressure of 350 bar and a flow capacity ranging from 90 l/min ($\frac{3}{8}$ "") to 600 l/min ($1\frac{1}{4}$ "").
- **Sensitive Control:** The DENISON poppet design delivers the minimum possible friction, superior hysteresis and optimum response to changes in operating conditions.
- **Wide Selection:** In addition to the various mounting options for the main valve body, or as cartridge for manifold applications, the ordering code offers a range of control options for valves and accessories. A solenoid vent valve is available (VV01).
- **Standardized Mounting:** Mounting configurations for R4 Pressure Controls are in accordance with international standards, and conform to ISO 6264. Vent valve option allows for remote pressure control.

SYMBOL

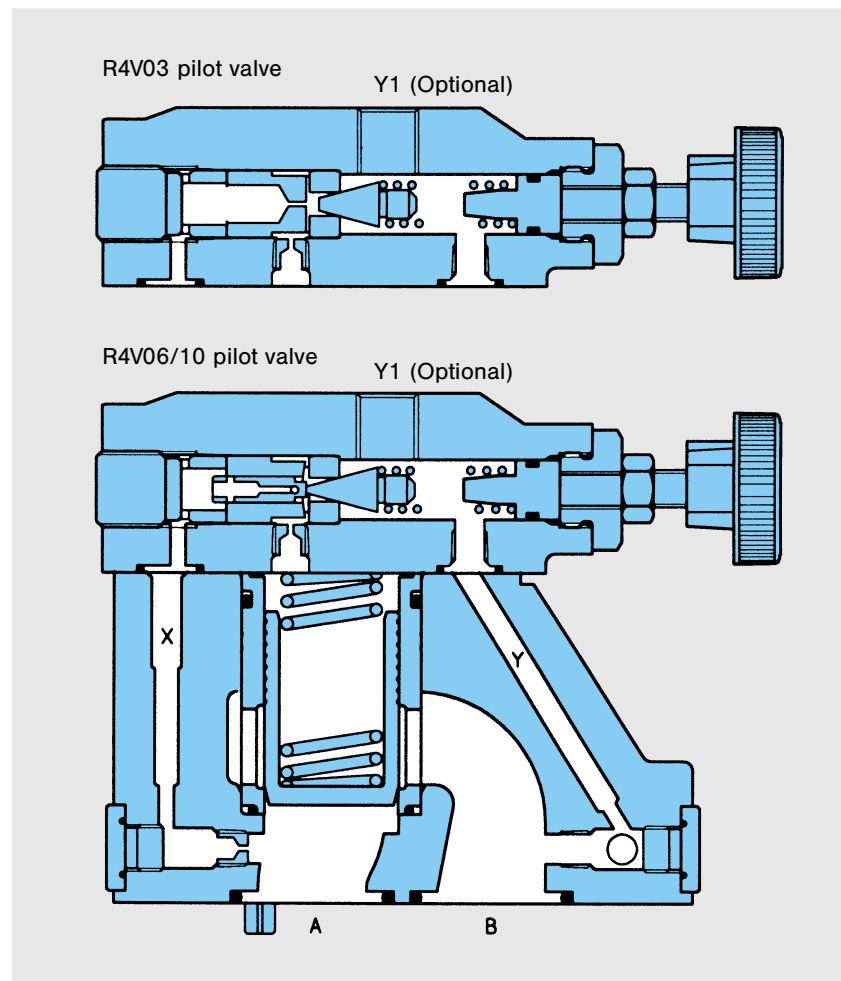
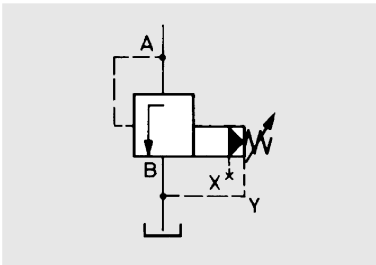

DESCRIPTION

GENERAL

DENISON Pressure Valves are pilot operated controls consisting of two or three sections; either a high flow, poppet type seat valve section controlled by the low flow, adjustable pilot mounted on top or in the case of the Proportional Pressure Relief Valve, the proportional section P2 sandwiched between the pilot stage and the main body.

R4V Relief Valves are used to limit the system pressure of a hydraulic circuit. Pressure is set by the control knob on the pilot, or according to the current input on the R4V . . . P2.

The R4V can be vented electrically by means of an optional vent valve, VV01. This valve is mounted between the pilot valve and the main body.

With the DENISON combined Seat Valve and Pilot design, and the range of springs available, it is possible to achieve extremely precise pressure setting.

All valve components are subject to rigorous quality control, based on international standards, thus permitting worldwide operation and interchangeable spare parts.

OPERATION

The system pressure in Port A is applied, via an orifice in X, to the pilot valve, the proportional valve (where present), and to the top surface of the main poppet. The hydraulically balanced main poppet is held against the seat by the main spring. In this state there is no flow through the valve.

The adjusted spring force acting on the pilot cone determines the relief pressure. If the pressure in Port A exceeds the set point, the pilot cone is lifted from its seat, releasing a small pilot flow to tank.¹⁾

The flow through the control orifice in X creates a pressure drop which limits the pressure at the top of the main poppet to the set point.

The higher system pressure in Port A now lifts the main poppet off its seat and allows flow to Port B.

In the resulting float position only enough flow is passed from Port A to Port B to maintain the inlet pressure in Port A at the set point.

When the pressure in Port A falls below the set point, the hydraulic balance on the main poppet is restored. The main spring then forces the main poppet to close.

¹⁾ The proportional valve P2 varies the pressure applied to the top of the main poppet, in proportion to the current input to the solenoid.

The manual setting of the pilot stage determines the maximum pressure and should be approximately 10% higher than the max. adjustable pressure of the proportional section (see also page 13).

The pilot drain chamber/proportional drain chamber is normally connected to Port B. Alternative external drain option through Port Y or Port Y1 available.

TECHNICAL DATA

GENERAL

- | | |
|---|--|
| <ul style="list-style-type: none"> • Type of unit • Design • Type of mounting | Pilot operated pressure relief
Poppet type
Threaded body
Subplate mounting
Cartridge |
| <ul style="list-style-type: none"> • Port sizes • Mounting position • Direction of flow • Ambient temperature range • Suitability for special working conditions | $\frac{3}{8}$ " , $\frac{3}{4}$ " , $1\frac{1}{4}$ " nominal
optional
A→B
– 20 ... + 60 °C
Consult DENISON |

HYDRAULIC CHARACTERISTICS

- | | | | | | | | | | | |
|---|---|-----------------------------------|----------------------------------|-----------------------------------|----------|-----------|-----------|----------|-----------|-----------|
| <ul style="list-style-type: none"> • Operating pressure range <ul style="list-style-type: none"> – inlet (port A) – outlet (port B) – port X – port Y, Y1 • Pressure setting range | 0 ... 350 bar
0 ... 30 bar
0 ... 350 bar
0 ... 30 bar
7 ... 350 bar | | | | | | | | | |
| <ul style="list-style-type: none"> • Nominal flow • Max. flow | <table border="0" style="width: 100%;"> <tr> <td style="width: 33%;">R4V03 ($\frac{3}{8}$")</td> <td style="width: 33%;">R4V06 ($\frac{3}{4}$")</td> <td style="width: 33%;">R4V10 ($1\frac{1}{4}$")</td> </tr> <tr> <td>60 l/min</td> <td>200 l/min</td> <td>450 l/min</td> </tr> <tr> <td>90 l/min</td> <td>300 l/min</td> <td>600 l/min</td> </tr> </table> | R4V03 ($\frac{3}{8}$ ") | R4V06 ($\frac{3}{4}$ ") | R4V10 ($1\frac{1}{4}$ ") | 60 l/min | 200 l/min | 450 l/min | 90 l/min | 300 l/min | 600 l/min |
| R4V03 ($\frac{3}{8}$ ") | R4V06 ($\frac{3}{4}$ ") | R4V10 ($1\frac{1}{4}$ ") | | | | | | | | |
| 60 l/min | 200 l/min | 450 l/min | | | | | | | | |
| 90 l/min | 300 l/min | 600 l/min | | | | | | | | |
| <ul style="list-style-type: none"> • Fluid | Petroleum base anti-wear fluids (covered by DENISON HF-0 and HF-2 specification). Such as mineral oil according to DIN 51524/25. Maximum catalogue ratings and performance data are based on operation with these fluids. | | | | | | | | | |
| <ul style="list-style-type: none"> • Fluid temperature range • Viscosity range • Recommended operating viscosity • Contamination level | – 18 °C ... + 80 °C
10 ... 650 cSt
30 cSt
Max. permissible contamination level according to NAS 1638 Class 8 (Class 9 for 15 micron and smaller) or ISO 17/14 | | | | | | | | | |

TYPE OF ADJUSTMENT

- | | |
|---|---|
| <ul style="list-style-type: none"> • Manual • Rotation • Operating torque • Electric (Vent valve VV01) • Nominal voltage • Permissible voltage difference • Max. coil temperature • Type of current • Input power • Holding • Inrush • Relative operating period • Type of protection • Electric proportional (pilot stage P2) | Handwheel
3.75 rev.
0.72 Nm
by solenoid
Refer to ordering code page 5
+ 5% ... – 10%
+ 180 °C (temperature class H)
Alternating current (AC)
Direct current (DC)
31 W
78 VA
264 VA
100%
IP 65
0 ... 2.5 A
(refer to publication 3–EN 2200) |
|---|---|

If the performance characteristics outlined above do not meet your requirements, please consult your local DENISON Office.

ORDERING CODE

	R4V												
1 Series	1	2	3	4	5	6	7	8	9	10	11	12	13
2 Size													
3 Max. Pressure													
4 Body Mounting													
5 Pressure Setting Range													
6 Type of Control													
7 Drain Line													
8 3-Way Vent Valve VV01													
9 P2 = Electric Proportional Pressure Control													
10 Solenoid Voltage and Current													
11 Design Letter													
12 Seal Class													
13 Modifications													

omit
for version
without VV01
& without P2

Model Number: _____

1 Series R4V = Pressure Relief Valve

2 Size
 03 = 3/8"
 06 = 3/4", 1"
 10 = 1 1/4"

3 Max. Pressure
 0 = for cartridges only } 350 bar
 5 = for body valves only }

4 Body Mounting
 Cartridge with pilot valve:
 0 = without Y1 port
 G = Y1 port = G 1/4"
 E = Y1 port = SAE-4 (7/16"-20 UNF)
 Subplate mounting:
 3 = without Y1 port
 9 = Y1 port = G 1/4"
 7 = Y1 port = SAE-4 (7/16"-20 UNF)
 Threaded body:
 6 = R4V03 = G 1/2" T-body }
 = R4V06 = G 1" T-body } X, Y1 ports¹⁾ = G 1/4"
 D = R4V06 = G 3/4" L-body }
 = R4V10 = G 1 1/4" L-body }
 4 = R4V03 = SAE-8 T-body }
 = R4V06 = SAE-16 T-body } X, Y1 ports¹⁾ = SAE-4
 B = R4V06 = SAE-12 L-body } (7/16"-20 UNF)
 = R4V10 = SAE-20 L-body }

¹⁾ Port Y1 is only available at **Drain line** (code 2) external from the pilot head

5 Pressure Setting Range
 1 = 7...105 bar
 3 = 7...210 bar
 5 = 7...350 bar

6 Type of Control
 1 = Hand knob 32 mm dia.
 2 = Hand knob 50 mm dia. (not for version with vent valve VV01 or P2)
 3 = Acorn nut with lead seal
 4 = Adjusting device with key lock, key order no. 700-70619-8

7 Drain Line
 0 = internal (not for cartridges)
 1 = external from the subplate or manifold (Y).
 2 = external from the pilot head (Y1); (not for **Body Mounting** codes 0 or 3)

8 3-Way Vent Valve VV01
 09 = with manual override } Solenoid de-energized: open to tank
 10 = without manual override } Solenoid energized: vent line blocked
 11 = with manual override } Solenoid de-energized: vent line blocked
 12 = without manual override } Solenoid energized: open to tank

9 P2 = Electric Proportional Pressure Control (12 V DC only) (not with internal drain code 0)

10 Solenoid Voltage and Current
 W01 = 115 V / 60 Hz }
 W02 = 230 V / 60 Hz } AC
 W06 = 115 V / 50 Hz }
 W07 = 230 V / 50 Hz }
 1) G0R = 12 V }
 G0Q = 24 V } DC
 G0H = 48 V }

11 Design Letter

12 Seal Class
 1 = NBR (Buna N) Standard 4 = EPDM 5 = FPM (Viton®)

13 Modifications

Please Note: R4V03 – Pilot heads are not interchangeability with R4V06 respectively R4V10 pilot heads.

CURVES

p-Q-CURVES

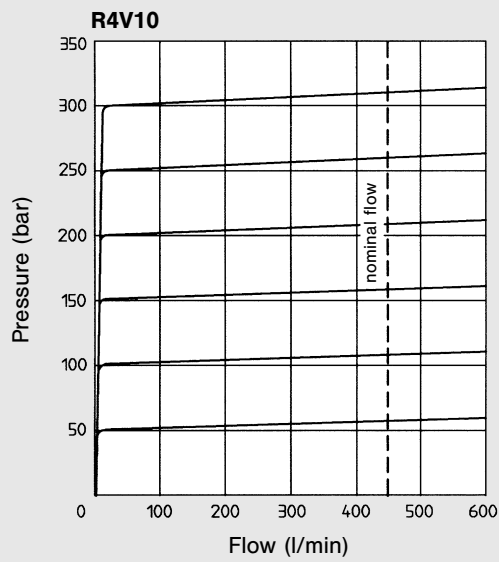
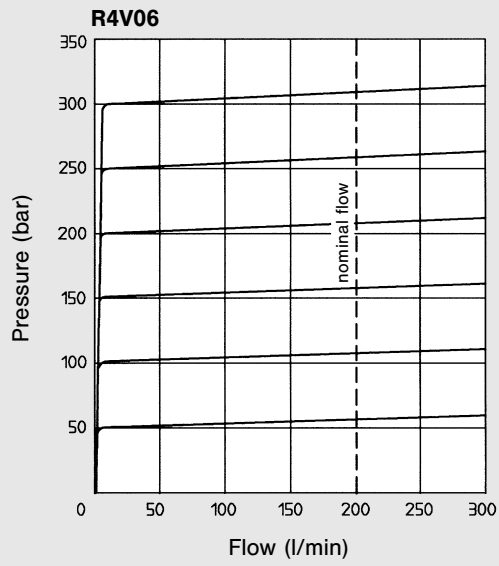
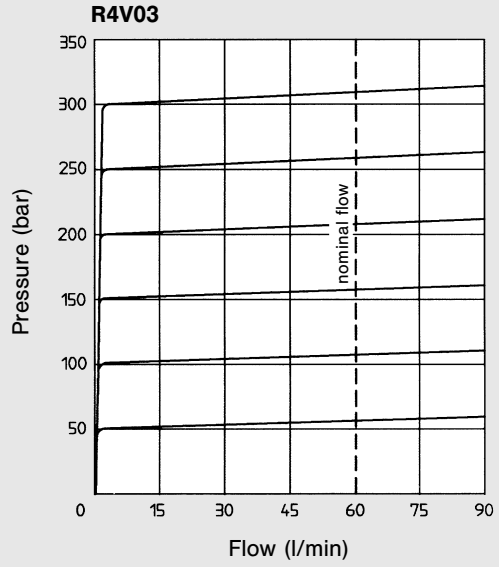

min. pressure setting ≥ 3 bar (depending on flow and viscosity).
Fluid 40 cSt at $50^\circ\text{C} \pm 0.5^\circ\text{C}$.

CARTRIDGES WITH PILOT VALVES

R4V03

0.6 kg

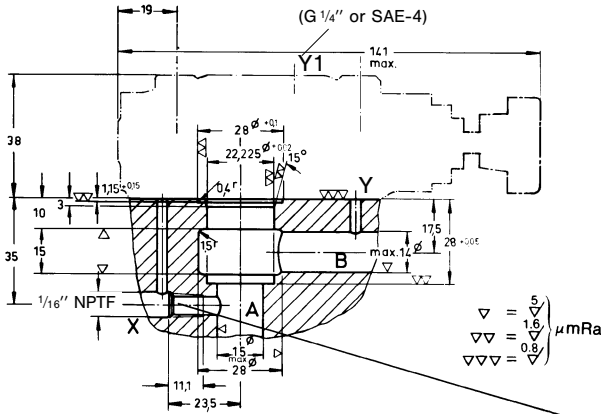

R4V06/10

1.2 kg

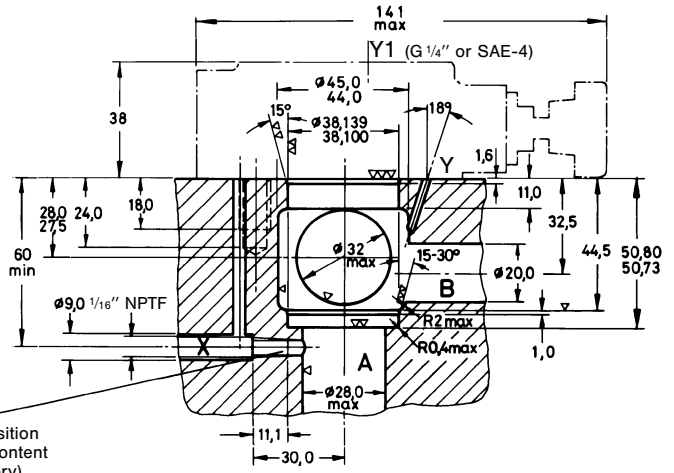

Orifice position
(orifice is content
of delivery)

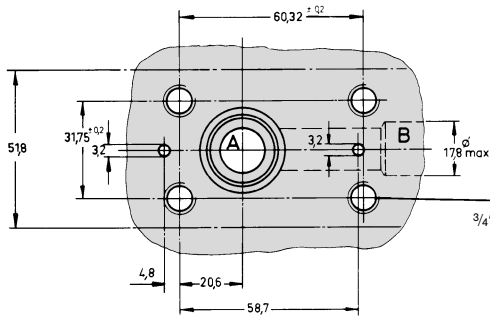

3/4"-24 UNF-3B or
M10 x 18.0 lg.

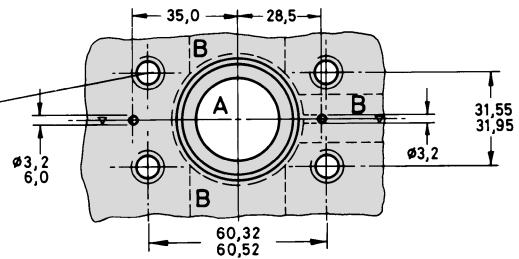

Ports	Function
A	Pressure (Inlet)
B*	Tank (Outlet)
X	external control connection
Y, Y1 ¹⁾	drain

* arrangement optional for R4V06 / R4V10

¹⁾ Port Y1 is only available at **Drain line** (code 2) external from the pilot head.

4 Mounting screws

Dimension	Order-No.
3/8"-24 UNF x 1 3/4" lg.	359-15220-0
or M10 x 45 mm, DIN 912-12.9	700-71602-8

(mounting screws must be ordered separately)
Torque 68 Nm

R4V03 (3/8") SUBPLATE MOUNTING

Weight: 2.7 kg

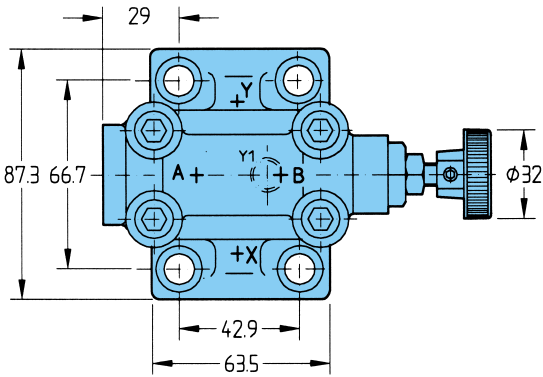
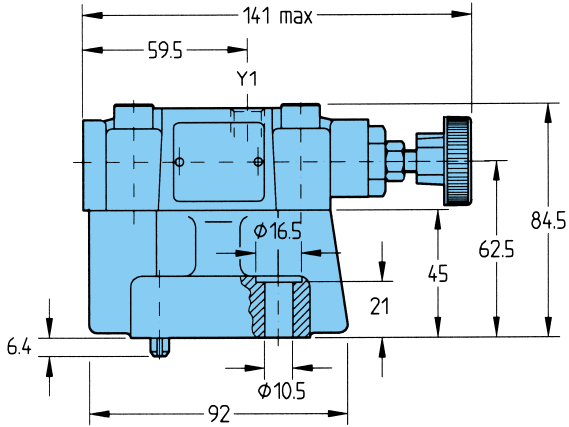

Ports	Function
A	Pressure (inlet)
B	Tank (outlet)
X	Remote control or vent connection
Y (Y1)	external drain ¹⁾

¹⁾ optional from pilot head or subplate. Port Y1 is only available at **Drain line** (code 2) external from the pilot head.

Panel opening

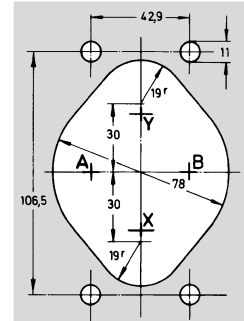

Block mounting face

Flatness 0.01 mm / 100 mm length

Surface finish CLA 1.27 µm

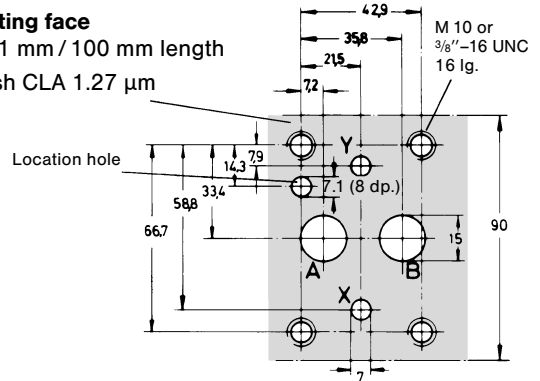

SUBPLATE

Weight: 2 kg

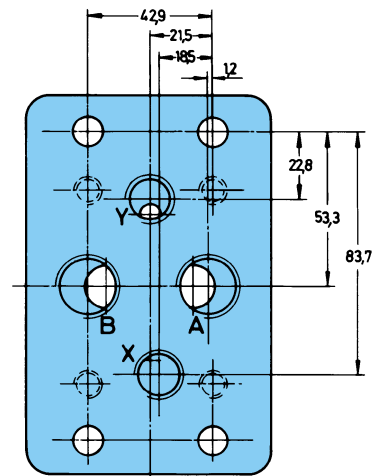
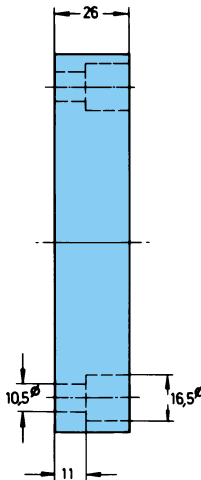
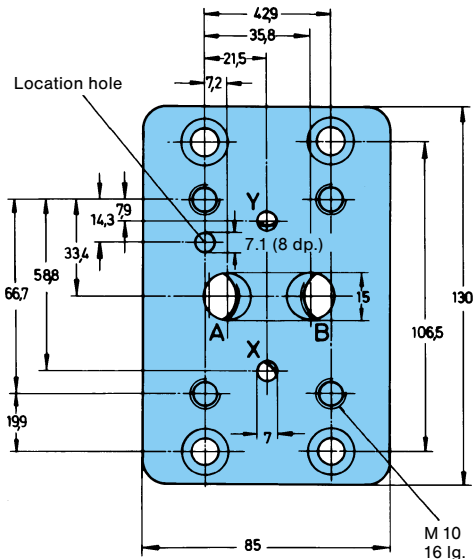

Model No.	Order No.	Port sizes		4 Mounting screws* (Torque 68 Nm)		
		A + B	X + Y	Dimension	Order No.	min. tensile strength
SS-B-08-G 113	S16-63124-0	G 1/2"	G 1/4"	M 10 x 35 DIN 912-12.9	700-70039-8	at p ≤ 210 bar = 100 daN/mm ² at p > 210 bar = 120 daN/mm ²

* Mounting screws are included in subplate order.
For valves ordered without subplate, mounting screws must be ordered separately.

R4V06 (3/4") SUBPLATE MOUNTING

Weight: 4.5 kg

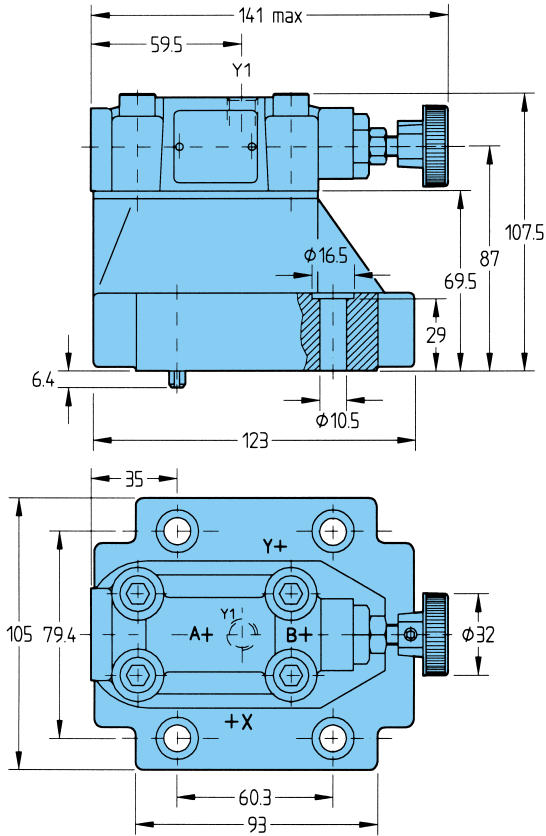

Ports	Function
A	Pressure (inlet)
B	Tank (outlet)
X	Remote control or vent connection
Y (Y1)	external drain ¹⁾

¹⁾ optional from pilot head or subplate. Port Y1 is only available at **Drain line** (code 2) external from the pilot head.

Panel opening

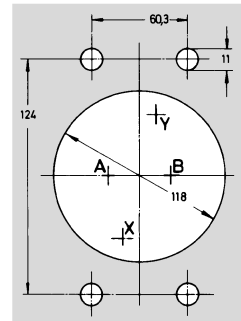

Block mounting face
Flatness 0.01 mm / 100 mm length
Surface finish CLA 1.27 µm

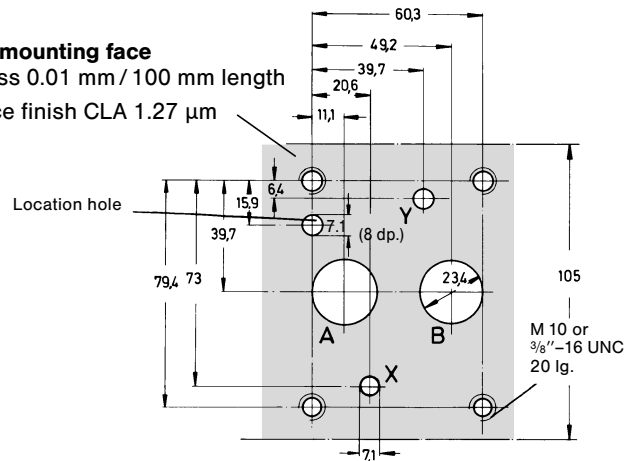

SUBPLATE

Weight: 4.8 kg

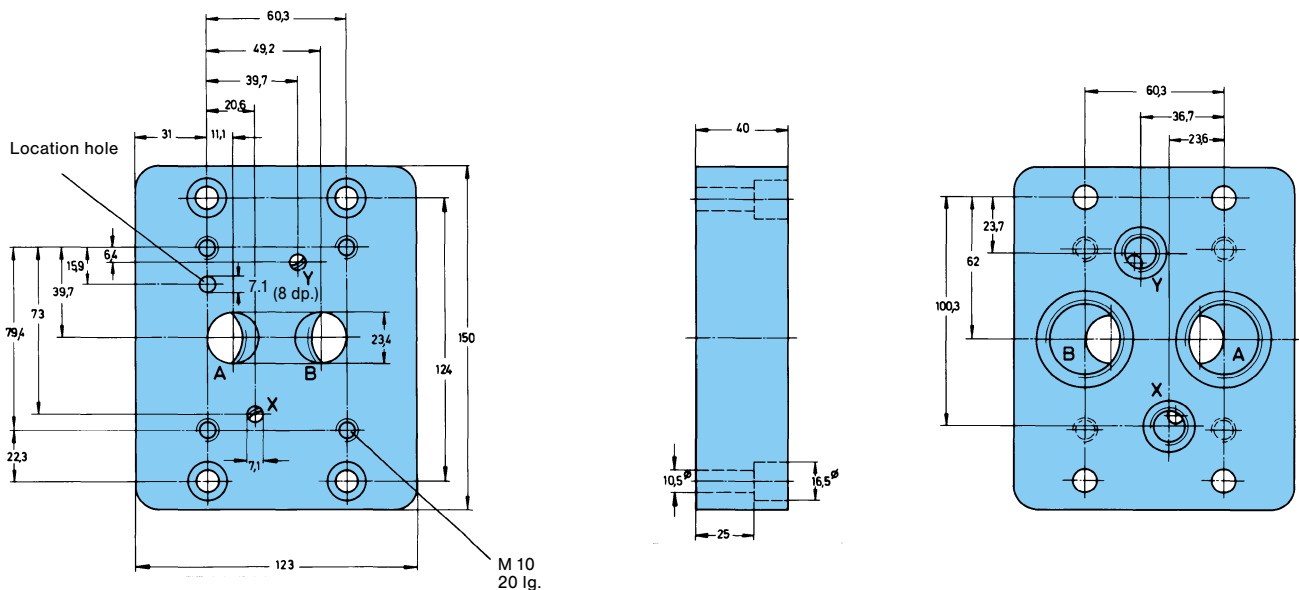

Model No.	Order No.	Port sizes		4 Mounting screws* (Torque 68 Nm)		
		A + B	X + Y	Dimension	Order No.	min. tensile strength
SS-B-16-G 115	S16-39168-0	G 1"	G 1/4"	M 10 x 45 DIN 912-12.9	700-71602-8	at p ≤ 210 bar = 100 daN/mm ² at p > 210 bar = 120 daN/mm ²

* Mounting screws are included in subplate order.
For valves ordered without subplate, mounting screws must be ordered separately.

R4V10 (1 1/4") SUBPLATE MOUNTING

Weight: 6 kg

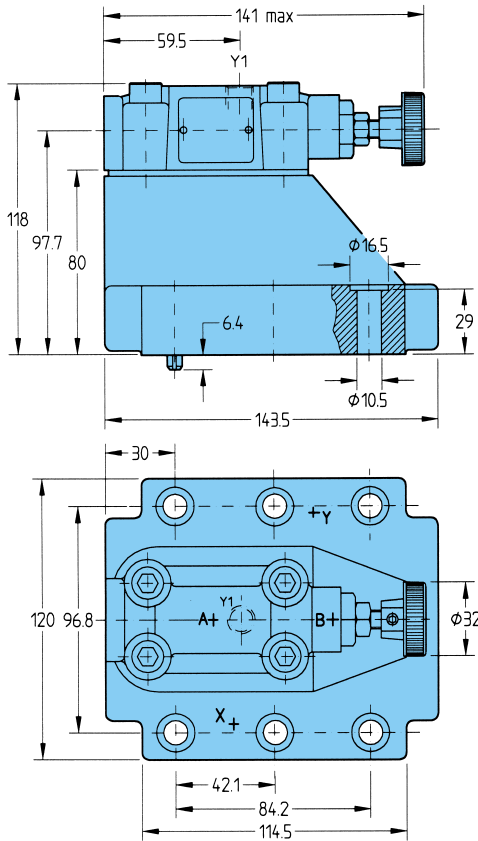

Ports	Function
A	Pressure (inlet)
B	Tank (outlet)
X	Remote control or vent connection
Y (Y1)	external drain ¹⁾

¹⁾ optional from pilot head or subplate. Port Y1 is only available at **Drain line** (code 2) external from the pilot head.

Panel opening

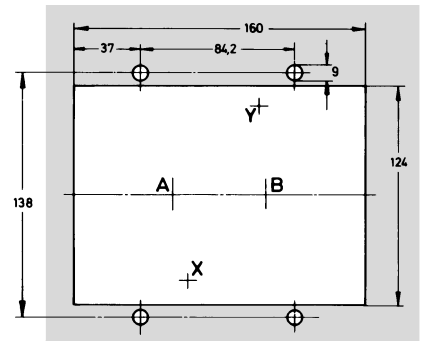

Block mounting face
 Flatness 0.01 mm / 100 mm length
 Surface finish CLA 1.27 µm

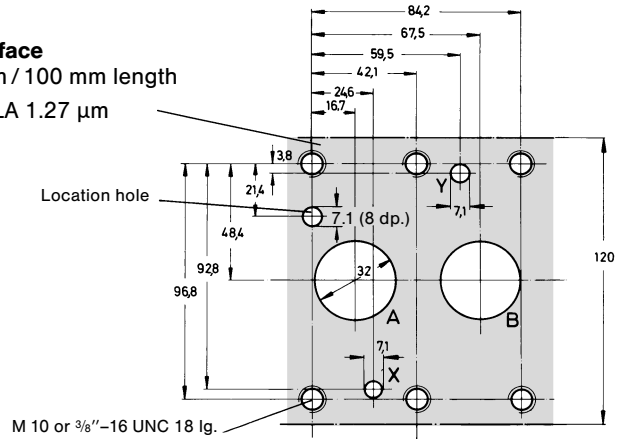

SUBPLATE

Weight: 8.5 kg

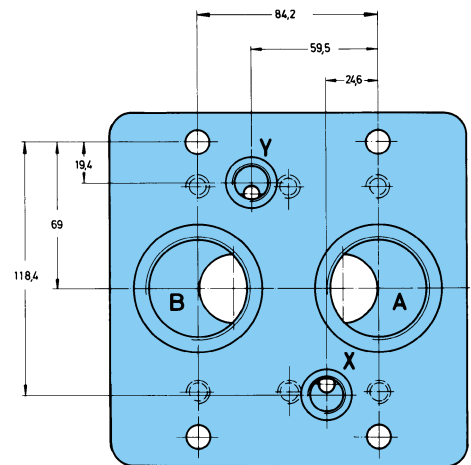
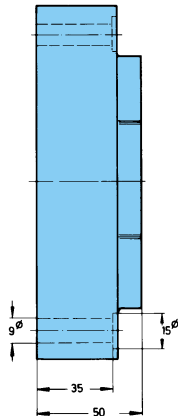
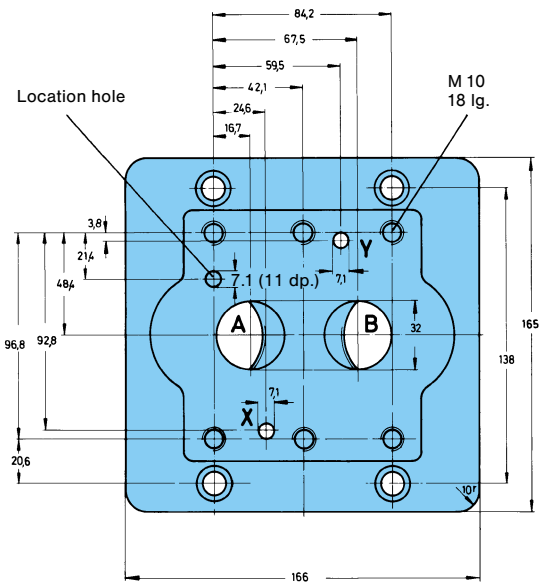

Model No.	Order No.	Port sizes		6 Mounting screws* (Torque 68 Nm)		
		A + B	X + Y	Dimension	Order No.	min. tensile strength
SS-B-24-G 117	S16-39197-0	G 1 1/2"	G 1/4"	M 10 x 45 DIN 912-12.9	700-71602-8	at p ≤ 210 bar = 100 daN/mm ² at p > 210 bar = 120 daN/mm ²

* Mounting screws are included in subplate order.
 For valves ordered without subplate, mounting screws must be ordered separately.

R4V03 (3/8") – R4V06 (3/4") THREADED BODY

R4V03 (3/8")

Weight: 3.2 kg

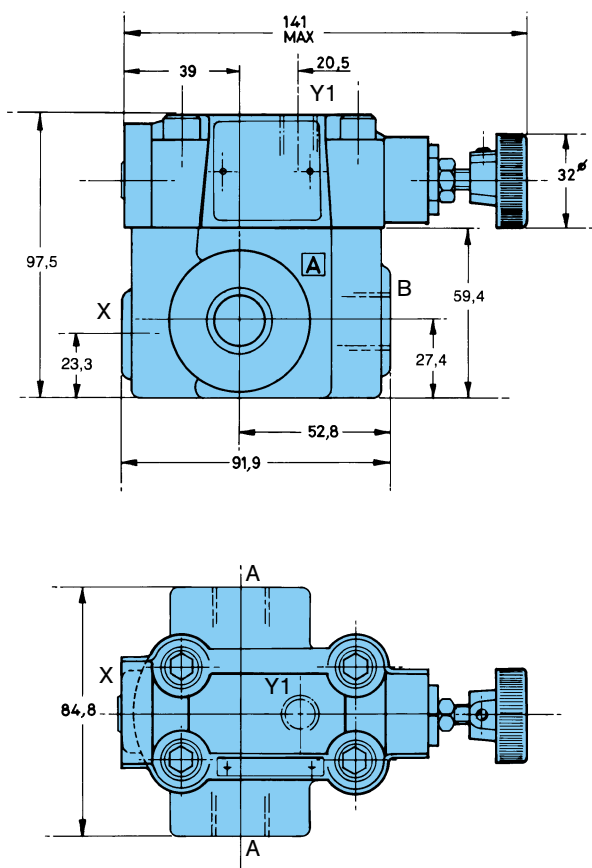

R4V06 (3/4")

Weight: 3.3 kg

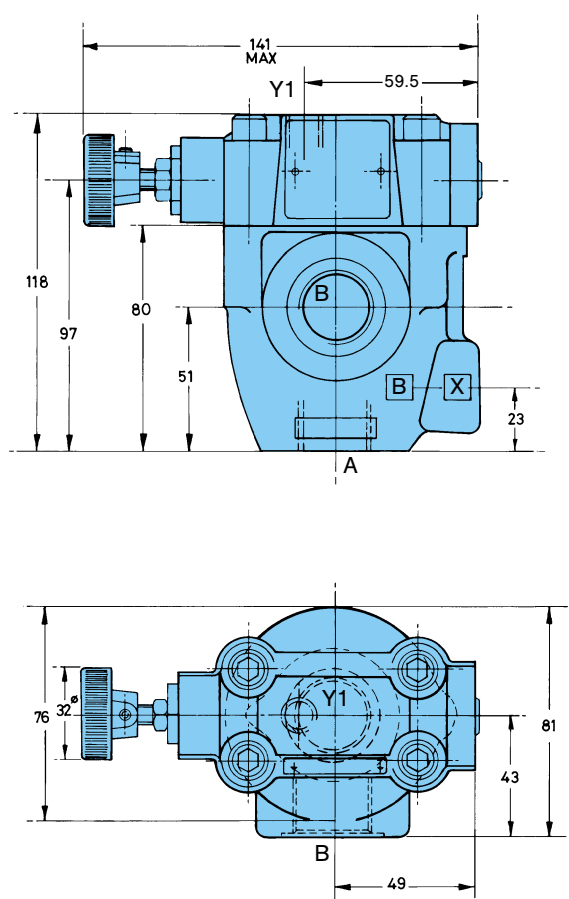

Ports	Function	Port Sizes
A (2)	Pressure (inlet)	G 1/2" or SAE-8 (3/4"-16 UNF)
B	Tank (outlet)	G 1/2" or SAE-8 (3/4"-16 UNF)
X ¹⁾	ext. remote control or vent connection	G 1/4" or SAE-4 (7/16"-20 UNF)
Y1 ²⁾	external drain	G 1/4" or SAE-4 (7/16"-20 UNF)

¹⁾ closed when supplied

²⁾ Port Y1 is only available at drain line (code 2) external from the pilot head

Ports	Function	Port Sizes
A	Pressure (inlet)	G 3/4" or SAE-12 (1 1/16"-12 UN)
B	Tank (outlet)	G 3/4" or SAE-12 (1 1/16"-12 UN)
X ¹⁾	ext. remote control or vent connection	G 1/4" or SAE-4 (7/16"-20 UNF)
Y1 ²⁾	external drain	G 1/4" or SAE-4 (7/16"-20 UNF)

¹⁾ closed when supplied

²⁾ Port Y1 is only available at drain line (code 2) external from the pilot head

R4V06 (3/4") – R4V10 (1 1/4") THREADED BODY

R4V06 (1")

Weight: 6.6 kg

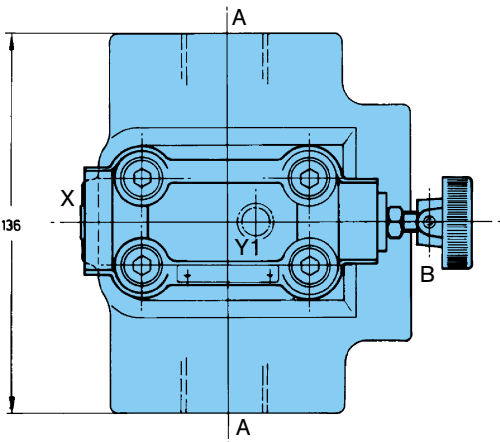
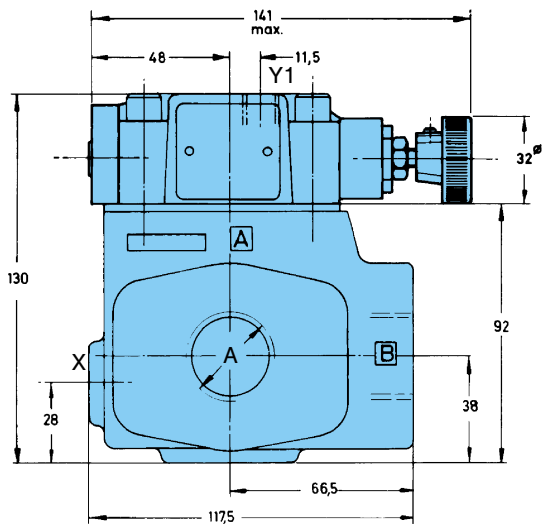

R4V10 (1 1/4")

Weight: 5.6 kg

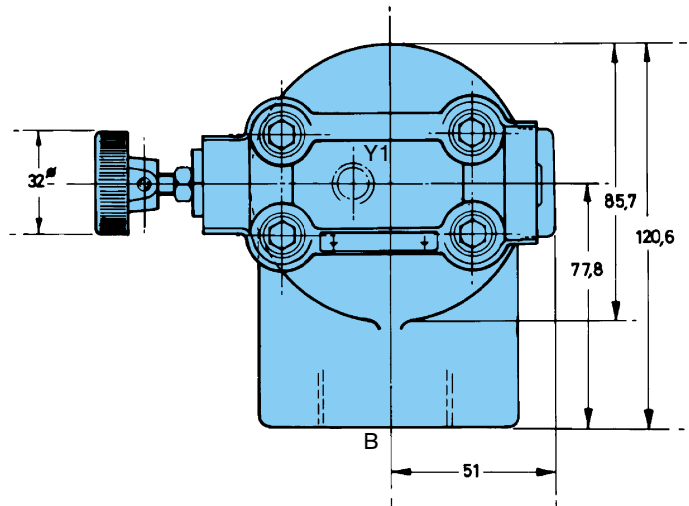
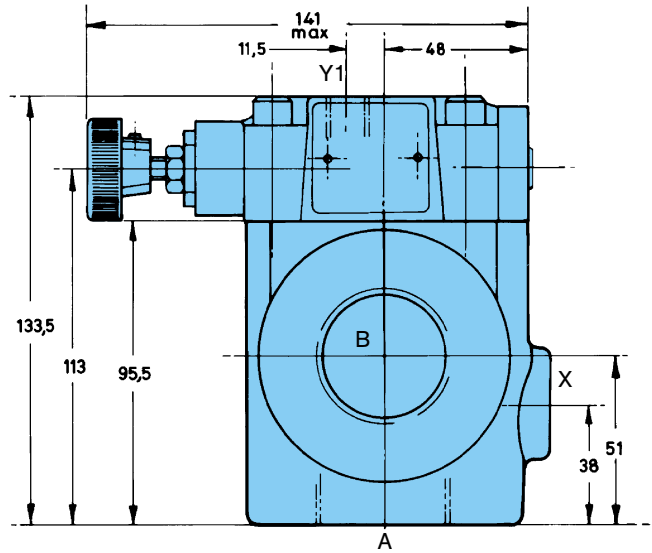

Ports	Function	Port Sizes
A (2)	Pressure (inlet)	G 1" or SAE-16 (1 5/16"-12 UN)
B	Tank (outlet)	G 1" or SAE-16 (1 5/16"-12 UN)
X ¹⁾	ext. remote control or vent connection	G 1/4" or SAE-4 (7/16"-20 UNF)
Y1 ²⁾	external drain	G 1/4" or SAE-4 (7/16"-20 UNF)

1) closed when supplied

2) Port Y1 is only available at drain line (code 2) external from the pilot head

Ports	Function	Port Sizes
A	Pressure (inlet)	G 1 1/4" or SAE-20 (1 5/8"-12 UN)
B	Tank (outlet)	G 1 1/4" or SAE-20 (1 5/8"-12 UN)
X ¹⁾	ext. remote control or vent connection	G 1/4" or SAE-4 (7/16"-20 UNF)
Y1 ²⁾	external drain	G 1/4" or SAE-4 (7/16"-20 UNF)

1) closed when supplied

2) Port Y1 is only available at drain line (code 2) external from the pilot head

PROPORTIONAL PRESSURE RELIEF VALVE R4V...P2

Screws for additional proportional section installation
 4 x 3/8"-24 UNF x 3 1/2" lg., order no. 359-15340-0.

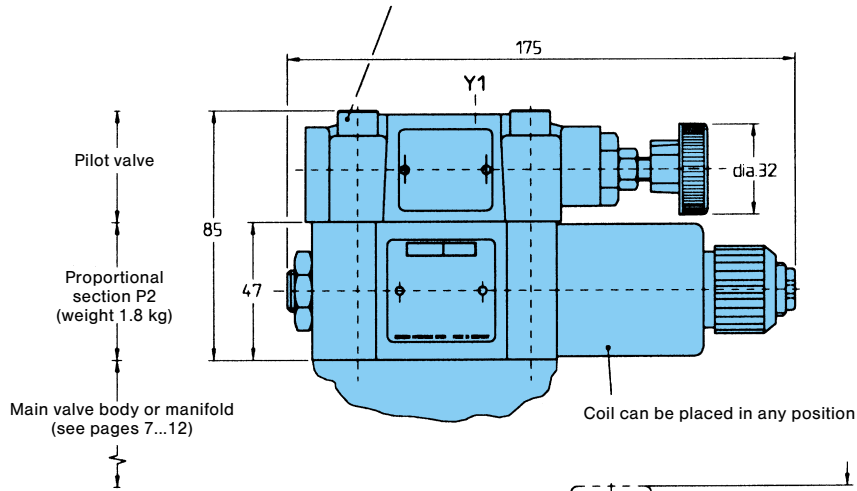

Drain Line:

- a) only external from the pilot head Y1, to a stable low pressure tank line (for threaded main stage)
- b) external from the pilot head Y1, or from the subplate Y to a stable low pressure tank line, (for subplate mounted main stage)

Symbol

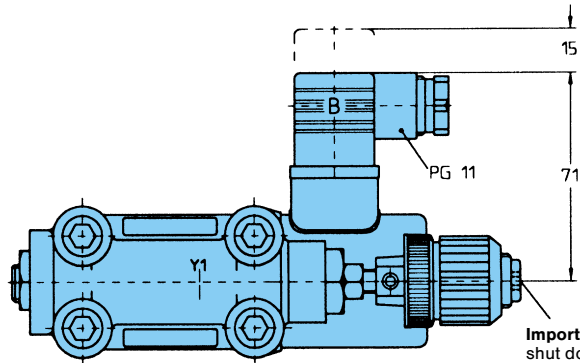
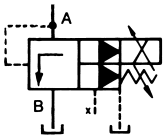

Distance required to remove plug-in connector.
 Plug-in connector supplied as standard.

Important: On initial start up and after long shut down periods bleed air from this plug.

Note:

See publication 3-EN 2200 for information on Electrical Proportional Control Valve.
 For additional installation with pilot operated control valves please consult DENISON.

VERSION WITH VENT VALVE VV01

Weight: (VV01): 1.7 kg

Screws for additional vent valve installation.
 4 x 3/8"-24 UNF x 3 1/2" lg., order no. 359-15340-0.

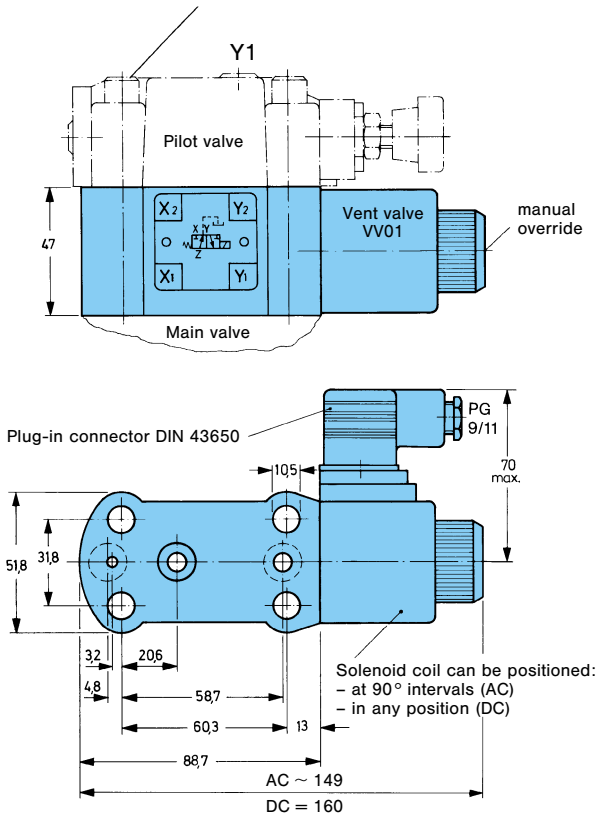

Symbols:
 R4V-Relief Valve with Vent Valve VV01

Code	Internal Drain	External Drain
11 or 12		
09 or 10		

Note:
 For full details of the vent valve VV01
 refer to bulletin 3-EN 2150.

ADDITIONAL TYPES OF CONTROL

Type of Control-Code 2
Hand knob 50 mm dia.
(not for version with
vent valve VV01 or P2)

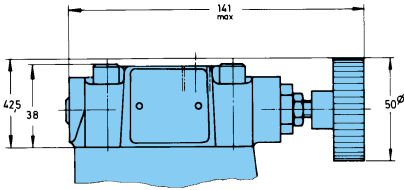

Type of Control-Code 3
Acorn nut with lead seal

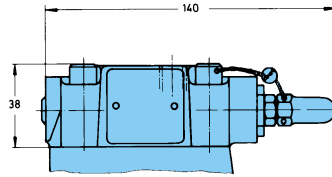

Type of Control-Code 4
Adjusting device with key lock.
Key must be ordered separately,
order-no. 700-70619-8

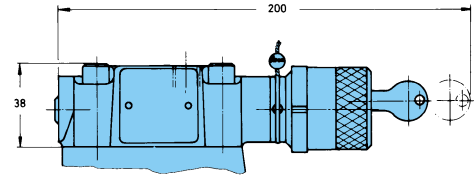

The product described is subject to continual development and the manufacturer reserves the right to change the specifications without notice.